

# SELF-PROPELLED SCISSOR LIFTS OPERATOR'S MANUAL

*with Maintenance Information*

( For S036-RS )



## WARNING

THE MANUFACTURER SHALL NOT BE HELD LIABLE IN CASE OF FAULTS OR ACCIDENTS DUE TO NEGLIGENCE, INCAPACITY, INSTALLATION BY UNQUALIFIED TECHNICIANS AND IMPROPER USE OF THE MACHINE

DO NOT OPERATE THIS MACHINE UNTIL YOU READ AND UNDERSTAND ALL THE DANGERS, WARNINGS AND CAUTIONS IN THIS MANUAL

Part Number: SM0115111A\_Rev2.2



Zhejiang Dingli Machinery Co., Ltd.

Second Edition, September 2018 Printing



## Important

Read, understand and obey these safety rules and operating instructions before operating this machine.

Only trained and authorized personnel shall be permitted to operate this machine. This manual should be considered a permanent part of your machine and should remain with the machine at all times. If you have any questions, please call DINGLI Machinery.

## Contents

---

	Page
Safety Rules	1
Legend	7
Decals	8
Specifications	11
Control panel	12
Pre-Operating Instructions	15
Workplace Inspection	17
Function Tests	18
Operating Instructions	23
Transport and Lifting Instructions	50
Maintenance	52
Schematic	73
Inspection and Repair Log	75

---

## Owners, Users and operators:

We appreciate your choice of our machine for your application. Our number one priority is user safety, which is best achieved by our joint efforts. We feel that you make a major contribution to safety if you, as the equipment users and operators:

- 1 Comply with employer, job site and governmental rules.
- 2 Read, understand and follow the instructions in this and other manuals supplied with this machine.
- 3 Use good safe work practices in a commonsense way.
- 4 Only have trained / certified operators, directed by informed and knowledgeable supervision, running the machine.

If there is anything in this manual that is not clear or which you believe should be added, please contact us.

---

## Contact us:

---

### Zhejiang Dingli Machinery Co., Ltd.

1255 Baiyun South Road. Leidian Town.

Deqing Zhejiang

China

Tel: +86-572-8681688

Fax: +86-572-8681690

Web: [www.cndingli.com](http://www.cndingli.com)

E-mail: [market@cndingli.com](mailto:market@cndingli.com)



## Safety Rules



### Danger

Failure to obey the instructions and safety rules in this manual will result in death or serious injury.

### Do Not Operate Unless:

- You learn and practice the principles of safe machine operation contained in this operator's manual.
  - 1 Avoid hazardous situations.**
  - Know and understand the safety rules before going on to the next section.**
  - 2 Always perform a pre-operation inspection.
  - 3 Always perform function tests prior to use.
  - 4 Inspect the workplace.
  - 5 Only use the machine as it was intended.
- You read, understand and obey the manufacturer's instructions and safety rules — operator's manual and machine decals.
- You read, understand and obey employer's safety rules and worksite regulations.
- You read, understand and obey all applicable governmental regulations.
- You are properly trained to safely operate the machine.

### Decal Legend

DINGLI product decals use symbols, color coding and signal words to identify the following:



**Safety alert symbol** — used to alert personnel to potential personal injury hazards. Obey all safety messages that follow this symbol to avoid possible injury or death.

**▲ DANGER** Red — used to indicate the presence of an imminently hazardous situation which, if not avoided, will result in death or serious injury.

**▲ WARNING** Orange — used to indicate the presence of a potentially hazardous situation which, if not avoided, could result in death or serious injury.

**▲ CAUTION** Yellow with safety alert symbol — used to indicate the presence of a potentially hazardous situation which, if not avoided, may cause minor or moderate injury.

**NOTICE** Blue without safety alert symbol — used to indicate the presence of a potentially hazardous situation which, if not avoided, may result in property damage.

## Safety Rules

### Intended Use

This machine is intended to be used only to lift personnel, along with their tools and materials to an aerial work site.

### Safety Sign Maintenance

Replace any missing or damaged safety signs. Keep operator safety in mind at all times. Use mild soap and water to clean safety signs. Do not use solvent-based cleaners because they may damage the safety sign material.

### ⚠ Electrocutation Hazard

This machine is not electrically insulated and will not provide protection from contact with or proximity to electrical current.



Maintain safe distances from electrical power lines and apparatus in accordance with applicable governmental regulations and the following chart.

Voltage Phase to Phase	Minimum Safe Approach Distance Meters
0 to 300V	Avoid Contact
300V to 50kV	3.05
50kV to 200kV	4.60
200kV to 350kV	6.10
350kV to 500kV	7.62
500kV to 750kV	10.67
750kV to 1000kV	13.72

Allow for platform movement, electrical line sway or sag and beware of strong or gusty winds.

Keep away from the machine if it contacts energized power lines. Personnel on the ground or in the platform must not touch or operate the machine until energized power lines are shut off.

Do not operate the machine during lightning or storms.

Do not use the machine as a ground for welding.

### ⚠ Tip-over Hazard

Occupants, equipment and materials must not exceed the maximum platform capacity or the maximum capacity of the platform extension.

#### Maximum capacity – S036-RS

Maximum occupants (Indoor use)	2
Maximum occupants (Outdoor use)	1
Platform allowable maximum load	240 kg
Extension deck allowable maximum load	100kg

Platform retracted



Platform extended



Extension only      Platform only

### Work Area Safety

Do not raise the platform unless the machine is on a firm, level surface.

Do not drive over 0.5 km/h with the platform raised.

## Safety Rules



Do not depend on the tilt alarm as a level indicator. The tilt alarm sounds on the chassis and in the platform when the machine is on a slope.

If the tilt alarm sounds:

Lower the platform. Move the machine to a firm, level surface. If the tilt alarm sounds when the platform is raised, use extreme caution to lower the platform.

For outdoor use machine, do not raise the platform when wind speeds may exceed 12.5 m/s. If wind speeds exceed 12.5 m/s when the platform is raised, lower the platform and do not continue to operate the machine.

Do not operate the machine in strong or gusty winds. Do not increase the surface area of the platform or the load. Increasing the area exposed to the wind will decrease machine stability.



Do not use the platform controls to free a platform that is caught, snagged or otherwise prevented from normal motion by an adjacent structure. All personnel must be removed from the platform before attempting to free the platform using the ground controls.

Use extreme care and slow speeds while driving the machine in the stowed position across uneven terrain, debris, unstable or

slippery surfaces and near holes and drop-offs.

Do not drive the machine on or near uneven terrain, unstable surfaces or other hazardous conditions with the platform raised.

Do not push off or pull toward any object outside of the platform.



### Maximum allowable manual force

Model	Application	manual force	Maximum occupants
S036-RS	Outdoor	200N	1
	Indoor	400N	2

Do not use the machine as a crane.

Do not place or attach fixed or overhanging loads to any part of this machine.

Do not push the machine or other objects with the platform.

Do not operate the machine with the chassis trays open.

Do not contact adjacent structures with the platform.

Do not alter or disable the limit switches.

Do not tie the platform to adjacent structures.

Do not place loads outside the platform perimeter.



## Safety Rules

Do not alter or disable machine components that in any way affect safety and stability.

Do not replace items critical to machine stability with items of different weight or specification.

Do not use batteries that weigh less than the original equipment. Batteries are used as counterweight and are critical to machine stability. Each battery must weigh 25 kg. The batteries must weigh a minimum of 50 kg.

Do not modify or alter an aerial work platform without prior written permission from the manufacturer. Mounting attachments for holding tools or other materials onto the platform, toe boards or guard rail system can increase the weight in the platform and the surface area of the platform or the load.

Do not place ladders or scaffolds in the platform or against any part of this machine.

Do not transport tools and materials unless they are evenly distributed and can be safely handled by person(s) in the platform.

Do not use the machine on a moving or mobile surface or vehicle.

Be sure all tires are in good condition, air-filled tires are properly inflated and lug nuts are properly tightened.

### ▲ Crushing Hazard

Keep hands and limbs out of scissors.

Keep hands clear when folding rails.

Maintain a firm grasp on the platform rail when removing the rail pins. Do not allow the platform guard rails to fall.

Use common sense and planning when operating the machine with the controller from the ground. Maintain safe distances between the operator, the machine and fixed objects.

### ▲ Operation on Slopes Hazard

Do not drive the machine on a slope that

exceeds the slope and side slope rating of the machine.

Slope rating applies to machines only in the stowed position.



Maximum slope rating stowed

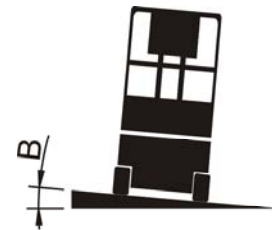

Maximum side slope rating stowed

Model	A	B
S036-RS	25% (14°)	25% (14°)

Note: Slope rating is subject to ground conditions and adequate traction.

### ▲ Fall Hazard

The guard rail system provides fall protection. During operation, occupants in the platform must wear a full body harness with a lanyard attached to an authorized lanyard anchorage point. Attach only one (1) lanyard per lanyard anchorage point.

Do not sit, stand or climb on the platform guard rails. Maintain a firm footing on the platform floor at all times.



Do not climb down from the platform when raised.



## Safety Rules

Keep the platform floor clear of debris.

Close the entry gate before operating.

Do not operate the machine unless the guard rails are properly installed and the entry is secured for operation.

Do not enter or exit the platform unless the machine is in the stowed position.

### ▲ Collision Hazard



Be aware of limited sight distance and blind spots when driving or operating.

Be aware of extended platform position(s) when moving the machine.

Check the work area for overhead obstructions or other possible hazards.



Be aware of crushing hazards when grasping the platform guard rail.

Operators must comply with employer, job site and governmental rules regarding use of personal protective equipment.

Observe and use color-coded direction arrows on the platform controls for drive and steer functions.

Do not operate a machine in the path of any crane or moving overhead machinery unless the controls of the crane have been locked out and/or precautions have been taken to prevent any potential collision.

No stunt driving or horseplay while operating a machine.

Do not lower the platform unless the area below is clear of personnel and obstructions.



Limit travel speed according to the condition of the ground surface, congestion, slope, location of personnel, and any other factors which may cause collision.

### ▲ Component Damage Hazard

Do not use any battery charger greater than 24V to charge the batteries.

Do not use the machine as a ground for welding.

### ▲ Explosion and Fire Hazard

Do not operate the machine or charge the batteries in hazardous locations where potentially flammable or explosive gases or particles may be present.

### ▲ Damaged Machine Hazard

Do not use a damaged or malfunctioning machine.

Conduct a thorough pre-operation inspection of the machine and test all functions before each work shift. Immediately tag and remove from service a damaged or malfunctioning machine.

Be sure all maintenance has been performed as specified in this manual.

Be sure all decals are in place and legible.

Be sure the operator's manual is complete, legible and in the storage container located in the platform.

## Safety Rules

### ▲ Bodily Injury Hazard

Do not operate the machine with a hydraulic oil or air leak. An air leak or hydraulic leak can penetrate and/or burn skin.

Improper contact with components under any cover will cause serious injury. Only trained maintenance personnel should access compartments. Access by the operator is only advised when performing a pre-operation inspection. All compartments must remain closed and secured during operation.

### ▲ Battery Safety

#### ▲ Burn Hazard



Batteries contain acid. Always wear protective clothing and eye wear when working with batteries.

Avoid spilling or contacting battery acid. Neutralize battery acid spills with baking soda and water.

#### ▲ Explosion Hazard

Keep sparks, flames and lighted tobacco away from batteries. Batteries emit explosive gas.

The battery tray should remain open during the entire charging cycle.



Do not contact the battery terminals or the cable clamps with tools that may cause sparks.

### ▲ Component Damage Hazard

Do not use any battery charger greater than 24V to charge the batteries.

### ▲ Electrocuting/ Burn Hazard



Connect the battery charger to a grounded, AC 3-wire electrical outlet only.

Inspect daily for damaged cords, cables and wires.

Replace damaged items before operating.

Avoid electrical shock from contact with battery terminals. Remove all rings, watches and other jewelry.

### ▲ Tip-over Hazard

Do not use batteries that weigh less than the original equipment. Batteries are used as counterweight and are critical to machine stability. Each battery must weigh 25 kg. The batteries must weigh a minimum of 50 kg.

### ▲ Lifting Hazard

Use the appropriate number of people and proper lifting techniques when lifting batteries.

## Lockout after Each Use

- 1 Select a safe parking location - firm level surface, clear of obstruction and traffic.
- 2 Lower the platform.
- 3 Turn the key switch to the off position and remove the key to secure from unauthorized use.
- 4 Push in the red Emergency Stop buttons to "off" position.
- 5 Push in the main power switch to "off" position
- 6 Chock the wheels.
- 7 Charge the batteries.

**Legend**

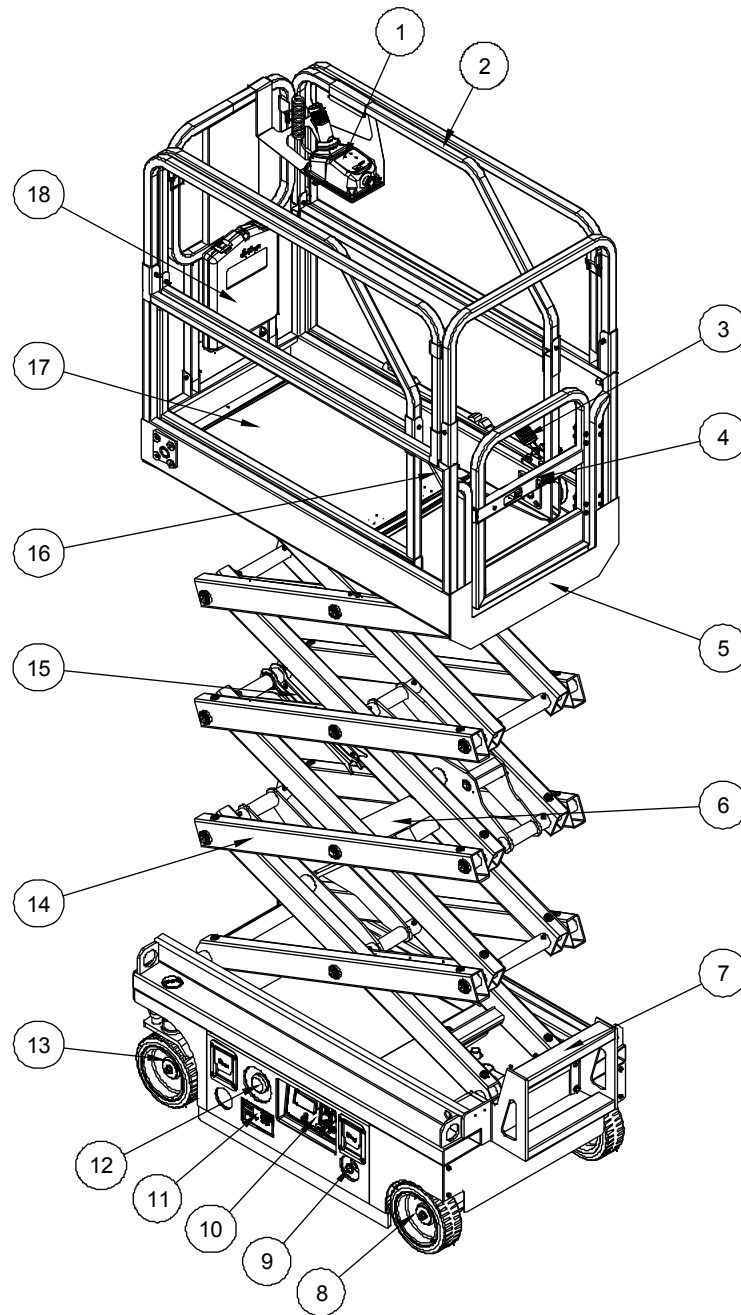

- |   |                                  |    |                          |
|---|----------------------------------|----|--------------------------|
| 1 | Platform control                 | 10 | Ground control           |
| 2 | Platform guard rails             | 11 | Battery charger          |
| 3 | Platform extension release pedal | 12 | Main power switch        |
| 4 | Platform entry gate              | 13 | Steer wheels             |
| 5 | Main platform                    | 14 | Scissor arms             |
| 6 | Lift cylinder                    | 15 | Safety arm               |
| 7 | Entry ladder                     | 16 | Lanyard anchorage point  |
| 8 | Drive wheels                     | 17 | Platform extension       |
| 9 | Emergency lowering knob          | 18 | Manual storage container |

## Decals

### Decal Inspection

Use the pictures on the next page to verify that all decals are legible and in place.

Below is a numerical list with quantities and descriptions.

No.	Part No.	Description	Qty.	Remark
1	09340001	Decal, Notice-Keep the manual with the machine	1	
2	09440003	Decal, Danger-Tip-over hazard, tilt-alarm	1	
3	09440001	Decal, Danger-General safety rules	1	
4	09340003	Decal, Instructions-Refer the operator to the instructions for use	2	
5	09440039	Decal, Label-Capacity 240kg	1	
6	09310001	Decal, Instructions-Forklift pockets	2	
7	09310003	Decal, Instructions-Tie down point	4	
8	09310002	Decal, Instructions-Lift point	4	
9	09310028	Decal, Instructions-Maximum wheel load 450kg	4	
10	09310004	Decal, Instructions-Emergency lower	1	
11	09310034	Decal, Notice-Main power switch operation	1	
12	09640042	Decal, Cosmetic-S036-RS	2	
13	09330001	Decal, Instructions-Safety arm	2	
14	09440009	Decal, Caution-Max. manual force 400N (Indoor) 200N (Outdoor)	2	
15	09940003	Decal, Label-E-Tech	2	
16	09440011	Decal, Label-Lanyard anchorage point	3	
17	09540001	Decal, Label-CE	1	
18	09210015	Nameplate, Manufacturer serial number	1	
19	09410001	Decal, Danger-Explosion/burn hazard	1	
20	09410003	Decal, Warning-Inspected and operation properly	1	

# Decals

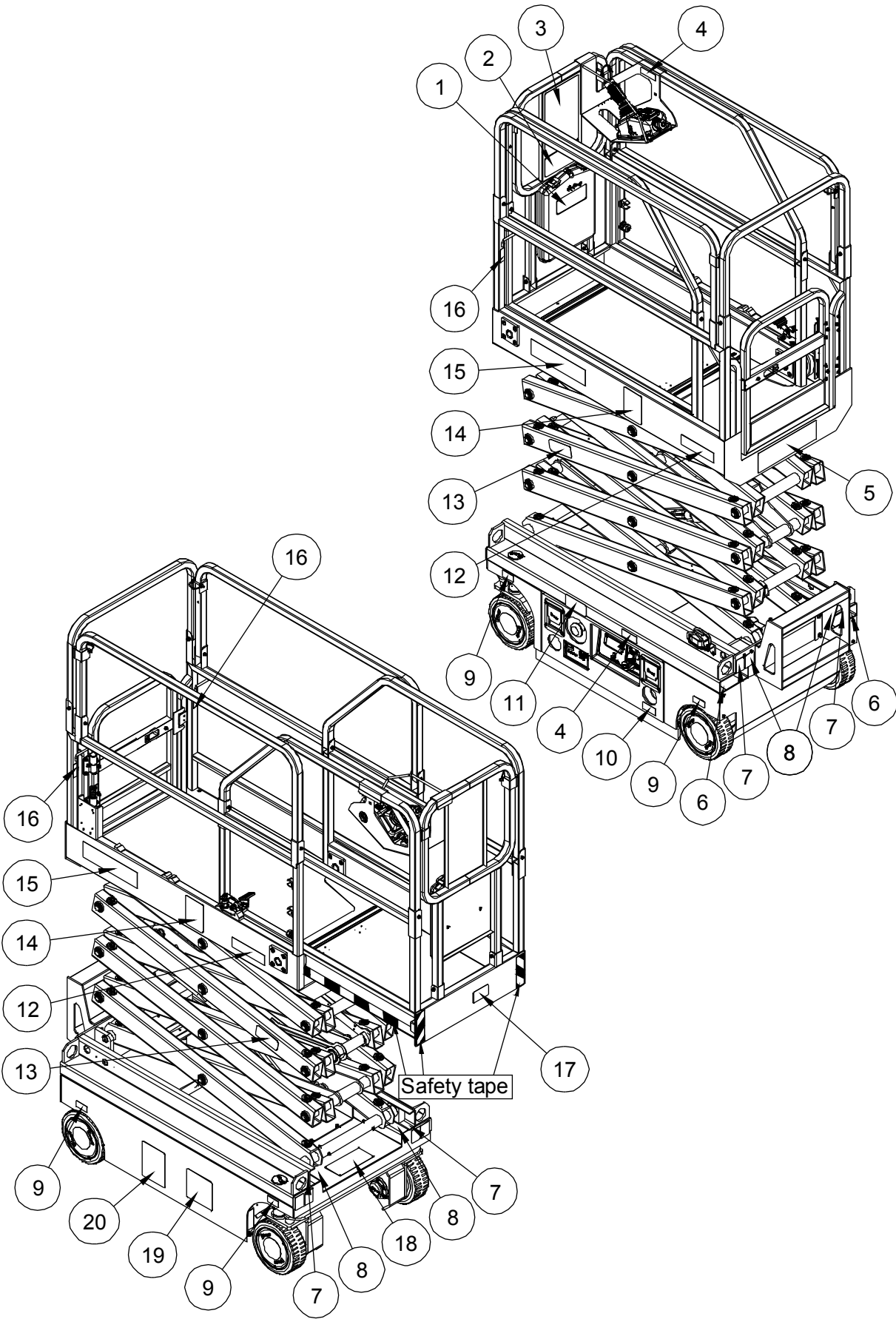

# Decals

① 09340001

**NOTICE**

**KEEP THE OPERATION AND SAFETY MANUAL WITH THE MACHINE**

09340001

② 09440003

**DANGER**

**Tip-over Hazard**

If lift-alarm sounds, unit is on a severe slope. Death or serious injury could occur.

1. Lower the platform.  
2. Move the machine to level surface.

09440003

③ 09440001

**DANGER**

Failure to read, understand and obey the operator's manual and the following safety rules will result in death or serious injury.

**Improper Use Hazard**

- Avoid hazardous situations.
- Always perform a pre-operation inspection.
- Always perform functional checks prior to use.
- Inspect work place.
- Only use the machine as it was intended.

Do not operate unless you are properly trained to safely operate this machine or you read, understand and obey the instructions and safety rules.

- Operator's manual and decals.
- Operator's safety rules.
- Applicable governmental regulations.

**Electrocution Hazards**

This machine is not electrically insulated and will not provide protection from contact with or proximity to electrical current.

Rated Voltage	Minimum Safe Approach Distance	Maximum
120 V AC	1.02 m	3.35 m
120 V to 208 V AC	1.52 m	4.97 m
208 V to 230 V AC	2.13 m	6.99 m
230 V to 250 V AC	2.74 m	9.01 m
250 V to 270 V AC	3.35 m	11.03 m
270 V to 300 V AC	3.96 m	13.05 m

**Tip-over Hazards**

- Do not exceed rated load capacity.
- Do not raise platform unless machine is on a firm surface.
- Avoid drop-offs, holes and unstable or slippery surfaces.
- Do not raise platform unless machine is on a level surface.
- Do not drive machine on a slope that exceeds the maximum slope or slope rating for the machine.
- Do not drive the machine on or near uneven terrain, unstable surfaces or other hazardous conditions with the platform raised.
- Do not push off or pull toward any object on side of the platform.
- Do not place or attach anything loads to any part of the machine.
- Use extreme care and slow speeds while driving the machine in sloped position across uneven terrain, dams, ripples or slippery surfaces and near holes and drop-offs.

**When not other or unsafe machine components that in any way affect safety and stability:**

- Do not use machine on uneven or platform or against any part of this machine.
- Do not use machine on a moving or mobile surface or surface.
- Do not use machine in poor conditions, unless use is properly lightened and other pins are properly installed.
- Do not raise platform when wind speeds may exceed 12 mph.
- Do not operate machine in strong or gusty winds.
- Do not increase surface area of platform or load. Increasing area exposed to wind will decrease machine stability.

**Fall Protection**

Manufacturer recommends that all persons in the platform wear a full body harness with a lanyard attached to an authorized tie-off anchor point while operating this machine.

**Fall Hazards**

When in operation, ensure all gates and rails are fastened and locked in ready position.

- Do not sit, stand or climb on the platform guard rails.
- Maintain a firm footing on the platform floor at all times.
- Do not climb down from the platform when raised.

**Crushing Hazards**

- Keep hands and limbs out of sections, slip common sense and caution when operating machine with platform raised.
- Maintain safe distance between operator, machine and fixed objects.

**Collision Hazards**

- Be aware of limited sight distance as load shifts when turning or backing.
- Watch work area for overhead obstructions or other possible hazards.
- Be aware of crushing hazard when grasping platform guard rail.
- Observe and use direction arrows on the platform controls for drive and lower functions.

**Damaged Machine Hazards**

- Do not use a damaged or malfunctioning machine.
- Be sure all maintenance has been performed as identified in the appropriate operator's manual.
- Use sure all decals are in place and legible.
- Use sure safety, operator's manual is complete, legible and in the storage compartment on the platform.

09440001

⑬ 09330001

09330001

⑯ 09440011

Reconnect only 1 Disconnect

⑰ 09540001

09540001

⑱ 09410001

**DANGER**

**Explosion/Burn Hazard**

Ignition of explosive gases or contact with corrosive acid will cause death, burns or blindness.

Keep all open flames and sparks away. Wear personal protective equipment, including face shield, gloves and long sleeve shirt.

**Read Manuals**

Read all manuals prior to operation.

**DO NOT OPERATE** equipment if you do not understand the information in the manuals. Consult your supervisor, the owner or the manufacturer.

09410001

⑤ 09440039

09440039

④ 09340003

Refer the operator to the instructions for use.

09340003

⑧ 09310002

09310002

⑥ 09310001

09310001

⑦ 09310003

09310003

⑨ 09310028

Maximum Wheel Load  
450 kg

09310028

⑩ 09310004

**EMERGENCY LOWER**

Pull knob to lower platform

09310004

⑪ 09310034

**NOTICE**

Cut off the power when the machine is repaired or not used for long period.

ON OFF

09310034

⑫ 09640042

# S036-RS

⑮ 09940003

# E-Tech

⑭ 09440009

**CAUTION**

Max. Manual Force

400N (Indoor)  
200N (Outdoor)

09440009

⑲ 09210015

**AERIAL WORK PLATFORM**

This product complies with Australian Standard AS/NZS1418: 10/2011

Model No. \_\_\_\_\_

Serial No. \_\_\_\_\_

Date of Manufacturer \_\_\_\_\_

Unloaded Mass \_\_\_\_\_

Rated Capacity \_\_\_\_\_

No. Occupants \_\_\_\_\_

Max. Manual Force \_\_\_\_\_

Max. Wind Speed \_\_\_\_\_

Max. Ground Slope \_\_\_\_\_

Voltage/Amperage \_\_\_\_\_

Rated Capacity of Attachments \_\_\_\_\_

Commission Date \_\_\_\_\_

Zhejiang Dingli Machinery Co., Ltd  
No. 1255 Baiyun South Rd, Leidian  
Town, Dingli, Zhejiang China  
Tel: 0086-572-8681688, 8681689  
Fax: 0086-572-8681690  
E-mail: market@dingli.com  
Http://www.cndingli.com

⑳ 09410003

**WARNING**

**THIS MACHINE MUST NOT BE USED UNTIL IT IS INSPECTED AND OPERATING PROPERLY.**

- Do not operate this machine unless you have been properly trained by a qualified person and authorized to operate this machine. Your training includes reading and understanding the safety, operating and maintenance instructions in manufacturer's manuals, knowing your employers work rules and applicable governmental regulations.
- Follow the instructions in the Operating Manual and applicable standards for daily, frequent, and annual inspections.
- Do not replace (items) i.e., batteries, wheels, counterweight, etc.) with items of different weight or specification because this will affect stability of machine.
- Do not modify or change machine without written approval from manufacturer.
- Operate this machine with extreme caution. STOP all operation if malfunction occurs.
- Improper use of this machine could cause death or serious injury.

09410003

**Specifications****S036-RS**

Height, working maximum	5.6 m	Maximum hydraulic pressure (functions)	155 bar
Height, platform maximum	3.6 m	System voltage	24 V
Height, stowed maximum Rails up	2.02 m	Tire size	Φ230×80 mm
Height, stowed maximum Rails folded	1.66 m	Airborne noise emissions	<70 dB
Width	0.76 m	Maximum sound level at normal operating workstations (A-weighted)	
Length, platform retracted	1.44 m	Vibration value does not exceed 2.5m/s <sup>2</sup>	
Length, platform extended	2.04 m	Maximum slope rating, Stowed position	25%
Platform dimensions Platform length × width	1.29×0.7 m	Maximum side slope rating, Stowed position	25%
Platform extension length	0.6 m	Note: Slope rating is subject to ground conditions and adequate traction.	
Maximum load capacity	240 kg	Maximum working slope	X-1.5°, Y-3°
Maximum wind speed	12.5 m/s	Drive speeds	
Wheelbase	1.05 m	Stowed, maximum	4.0 km/h
Turning radius (outside)	1.55 m	Platform raised, maximum	0.5 km/h
Turning radius (inside)	0.4 m	Floor loading information	
Ground clearance	6 cm	Tire load, maximum	450 kg
Ground clearance Pothole guards deployed	1.5cm	Tire contact pressure	8 kg/cm <sup>2</sup> 784 kPa
Weight (See Serial Label)		Occupied floor pressure	1138 kg/m <sup>2</sup> 11.2 kPa
Machine weights vary with option configurations		Note: Floor loading information is approximate and does not incorporate different option configurations. It should be used only with adequate safety factors.	
Power source	2 Batteries , 12V 85Ah		
Controls	Proportional		
AC outlet in platform	Standard		

Continuous improvement of our products is a DINGLI policy. Product specifications are subject to change without notice or obligation

## Control Panel

### Ground Control Panel

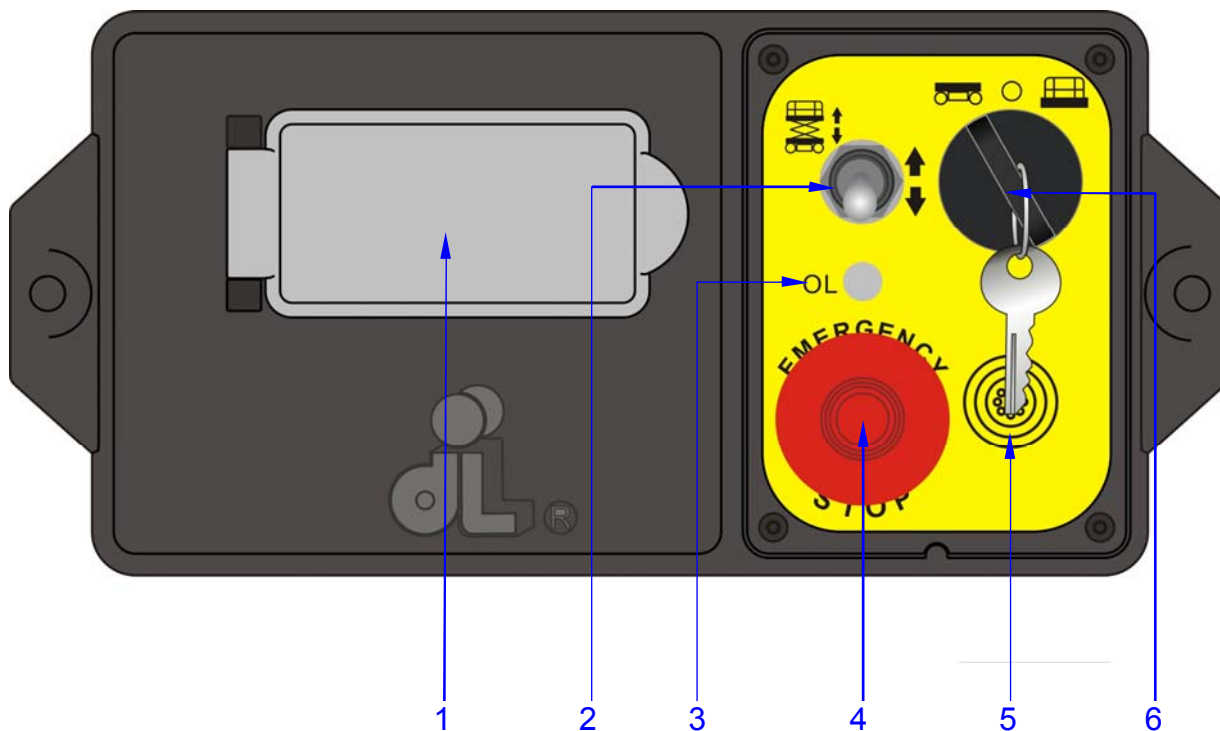

1 LED readout screen

Diagnostic readout

2 Platform up / down switch

Move the switch up and the platform will raise.

Move the switch down and the platform will lower.

3 Overload indicator light

Light on indicates when overloaded.

4 Red Emergency Stop button

Push in the red Emergency Stop button to the off position to stop all functions. Pull out the red Emergency Stop button to the on position to operate the machine.

5 Alarm

6 Key switch

Turn the key switch to the platform position and the platform controls will operate. Turn the key switch to the off position and the machine will be off. Turn the key switch to the ground position and the ground controls will operate.



## Control Panel

### Platform Control Panel

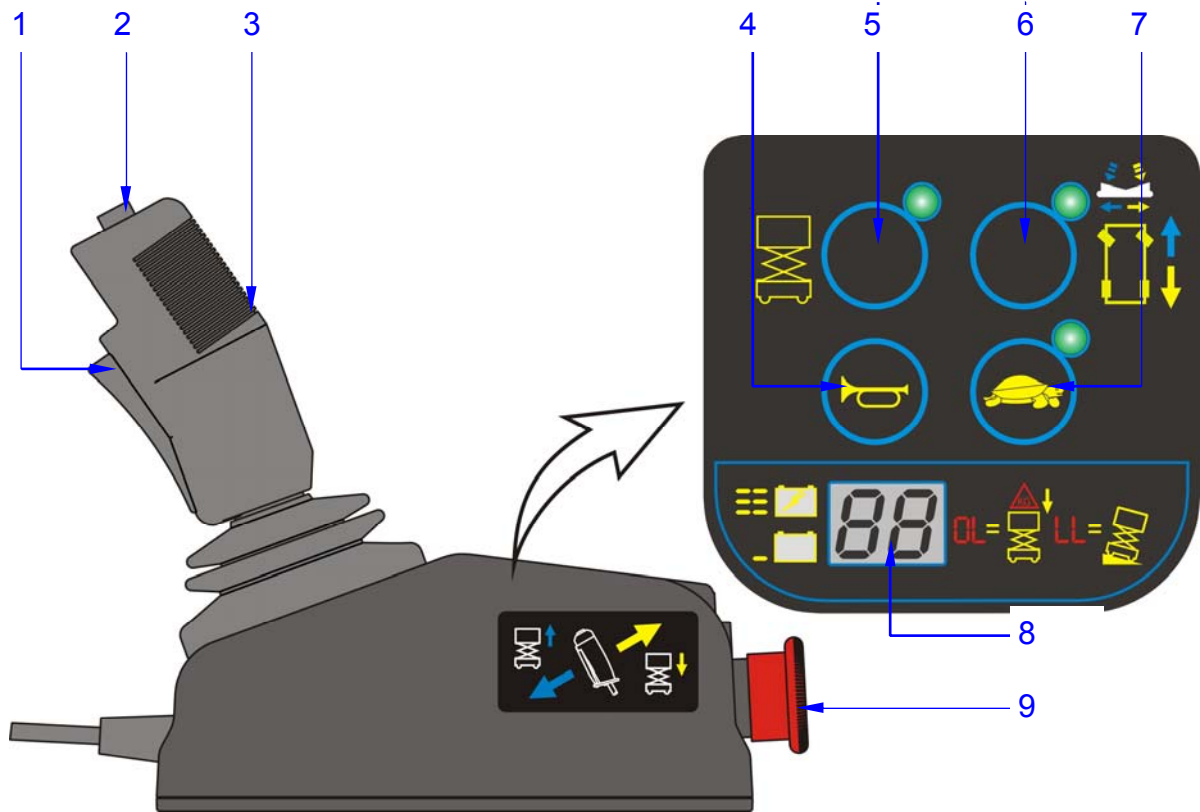

- 1 Function enable switch
- 2 Thumb rocker switch
- 3 Proportional control handle
- 4 Horn button
- 5 Lift function select button

- 6 Drive function select button
- 7 Drive speed button
- 8 LED readout screen
- 9 Red Emergency Stop button

## Control Panel

### Platform Control Panel

1 Function enable switch

Press and hold the function enable switch to enable the drive/lift function.

2 Thumb rocker switch

Press the thumb rocker switch in either direction to activate steer function.

3 Proportional control handle

Lift function: Press and hold the function enable switch to enable the lift function on the platform control handle. Move the control handle in the direction indicated by the blue arrow and the platform will raise. Move the control handle in the direction indicated by the yellow arrow and the platform will lower. The descent alarm should sound while the platform is lowering.

Drive function: Press and hold the function enable switch to enable the drive function on the platform control handle. Move the control handle in the direction indicated by the blue arrow on the control panel and the machine will move in the direction that the blue arrow points. Move the control handle in the direction indicated by the yellow arrow on the control panel and the machine will move in the direction that the yellow arrow points.

4 Horn Button

Press this button and the horn will sound. Release the button and the horn will stop.

5 Lift function select button

Press this button to activate the lift function.

6 Drive function select button

Press this button to activate the drive function.

7 Drive speed button

Press this button to activate the drive function.

8 LED readout screen

Diagnostic read out and battery charge indicator.

9 Red Emergency Stop button

Push in the red Emergency Stop button to the off position to stop all functions. Pull out the red Emergency Stop button to the on position to operate the machine.

## Pre-operation Inspection



### Do Not Operate Unless:

You learn and practice the principles of safe machine operation contained in this operator's manual.

- 1 Avoid hazardous situations.
- 2 **Always perform a pre-operation inspection.**

**Know and understand the pre-operation inspection before going on to the next section.**

- 3 Inspect the workplace.
- 4 Always perform function tests prior to use.
- 5 Only use the machine as it was intended.

### Fundamentals

It is the responsibility of the operator to perform a pre-operation inspection and routine maintenance.

The pre-operation inspection is a visual inspection performed by the operator prior to each work shift. The inspection is designed to discover if anything is apparently wrong with a machine before the operator performs the function tests.

The pre-operation inspection also serves to determine if routine maintenance procedures are required. Only routine maintenance items specified in this manual may be performed by the operator.

Refer to the list on the next page and check each of the items.

If damage or any unauthorized variation from factory delivered condition is discovered, the machine must be tagged and removed from service.

Repairs to the machine may only be made by a qualified service technician, according to the manufacturer's specifications. After repairs are completed, the operator must perform a pre-operation inspection again before going on to the function tests.

Scheduled maintenance inspections shall be performed by qualified service technicians, according to the manufacturer's specifications and the requirements listed in this manual.

## Pre-operation Inspection

### Pre-operation Inspection

- Be sure that the operator's manual are complete, legible and in the storage container located in the platform.
- Be sure that all decals are legible and in place. See Decals section.
- Check for hydraulic oil leaks and proper oil level. Add oil if needed. See Maintenance section.
- Check for battery fluid leaks and proper fluid level. Add distilled water if needed. See Maintenance section.

Check the following components or areas for damage, improperly installed or missing parts and unauthorized modifications:

- Electrical components, wiring and electrical cables
- Hydraulic hoses, fittings, cylinders and manifolds
- Battery pack and connections
- Drive motors
- Wear pads
- Tires and wheels
- Ground strap
- Limit switches, alarm, beacon and Rotary sensor
- Nuts, bolts and other fasteners
- Platform overload components
- Platform entry gate
- Safety arm
- Platform extension(s)
- Scissor pins and retaining fasteners
- Platform control joystick
- Brake release components
- Pothole guard

Check entire machine for:

- Cracks in welds or structural components
- Dents or damage to machine
- Be sure that all structural and other critical components are present and all associated fasteners and pins are in place and properly tightened
- Be sure side rails are installed and rail pins and bolts are fastened.
- Be sure that the chassis trays are closed and latched and the batteries are properly connected.

Note: If the platform must be raised to inspect the machine, make sure the safety arm is in place. See Operating Instructions section.

## Workplace Inspection



### Do Not Operate Unless:

You learn and practice the principles of safe machine operation contained in this operator's manual.

- 1 Avoid hazardous situations.
- 2 Always perform a pre-operation inspection.
- 3 Inspect the workplace.**

**Know and understand the workplace inspection before going on to the next section.**

- 4 Always perform function tests prior to use.
- 5 Only use the machine as it was intended.

### Fundamentals

The workplace inspection helps the operator determine if the workplace is suitable for safe machine operation. It should be performed by the operator prior to moving the machine to the workplace.

It is the operator's responsibility to read and remember the workplace hazards, then watch for and avoid them while moving, setting up and operating the machine.

### Workplace Inspection

Be aware of and avoid the following hazardous situations:

- Drop-offs or holes
- Bumps, floor obstructions or debris
- Sloped surfaces
- Unstable or slippery surfaces
- Overhead obstructions and high voltage conductors
- Hazardous locations
- Inadequate surface support to withstand all load forces imposed by the machine
- Wind and weather conditions
- The presence of unauthorized personnel
- Other possible unsafe conditions

## Function Tests



### Do Not Operate Unless:

You learn and practice the principles of safe machine operation contained in this operator's manual.

- 1 Avoid hazardous situations.
- 2 Always perform a pre-operation inspection.
- 3 Inspect the workplace.
- 4 **Always perform function tests prior to use.**

**Know and understand the function tests before going on to the next section.**

- 5 Only use the machine as it was intended.

### Fundamentals

The function tests are designed to discover any malfunctions before the machine is put into service.

The operator must follow the step-by-step instructions to test all machine functions.

A malfunctioning machine must never be used. If malfunctions are discovered, the machine must be tagged and removed from service.

Repairs to the machine may only be made by a qualified service technician, according to the manufacturer's specifications.

After repairs are completed, the operator must perform a pre-operation inspection and function tests again before putting the machine into service.

## Function Tests

- 1 Select a test area that is firm, level and free of obstruction.
- 2 Be sure the battery pack is connected.
- 3 Pull out the main power switch to "on" position.

### At the Ground Controls

- 4 Pull out the red Emergency Stop button to the on position at both the ground and platform controls.
- 5 Turn the key switch to ground control.
- 6 Observe the LED readout screen on the ECU window.

- ⊙ Result: The LED should look like the picture at underside



### Test Emergency Stop

- 7 Push in the ground red Emergency Stop button to the off position.
- ⊙ Result: No functions should operate.
- 8 Pull out the red Emergency Stop button to the on position.

### Test Up/Down Functions

A buzzer with different sound frequency is controlled in central system. The descent alarm sounds at 60 beeps per minute. The descent delay alarm sounds at 120 beeps per minute. The alarm that goes off when the pothole guards have not deployed sounds at 180 beeps per minute. The alarm that goes off when the machine is not level sounds at 180 beeps per minute. An optional automotive-style horn is also available.

- 9 Turn the key switch to off or platform position.
- 10 Move up and hold the platform up / down switch.

- ⊙ Result: No function should operate.

- 11 Turn the key switch to ground control position.
- 12 Move up and hold the platform up / down switch.

- ⊙ Result: The platform should raise.

- 13 Move down and hold the platform up / down switch.

- ⊙ Result: The platform should lower. The descent alarm should sound while the platform is lowering. The platform stop at the height is approximately 1.3m from the ground. The descent delay alarm will sound.

Note: Be sure the area below the platform is clear of personnel and obstructions before continuing.

- 14 Move down and hold the platform up / down switch.

- ⊙ Result: The platform should lower to end. The descent delay alarm should sound while the platform is lowering.

### Test the Emergency Lowering

- 15 Activate the up function and raise the platform approximately 60 cm.

- 16 Pull the emergency lowering knob.

- ⊙ Result: The platform should lower. The descent alarm will not sound.

- 17 Turn the key switch to platform control.

## Function Tests

### At the Platform Controls

#### Test Emergency Stop

- 18 Push in the platform red Emergency Stop button to the off position.
- ⊙ Result: No functions should operate.
- 19 Pull out the red Emergency Stop button to the on position.
- ⊙ Result: The LED indicator light should come on.

#### Test the Horn

- 20 Push the horn button.
- ⊙ Result: The horn should sound.

#### Test Function Enable and Up/Down Functions

- 21 Do not hold the function enable switch on the control handle.
- 22 Slowly move the control handle in the direction indicated by the blue arrow, then in the direction indicated by the yellow arrow.
- ⊙ Result: No functions should operate.
- 23 Press the lift function select button.
- 24 Press and hold the function enable switch on the control handle.
- 25 Slowly move the control handle in the direction indicated by the blue arrow.
- ⊙ Result: The platform should raise. The pothole guards should deploy.
- 26 Release the control handle.
- ⊙ Result: The platform should stop raising.
- 27 Press and hold the function enable switch. Slowly move the control handle in the direction indicated by the yellow arrow.
- ⊙ Result: The platform should lower. The descent alarm should sound while the platform is lowering.

### Test the Steering

Note: When performing the steer and drive function tests, stand in the platform facing the steer end of the machine.

- 28 Press the drive function select button. The indicator light should turn on.
- 29 Press and hold the function enable switch on the control handle.
- 30 Depress the thumb rocker switch on top of the control handle in the direction identified by the blue left arrow on the control panel.
- ⊙ Result: The steer wheels should turn in the direction that the blue left arrow points on the control panel.
- 31 Depress the thumb rocker switch in the direction identified by the yellow right arrow on the control panel.
- ⊙ Result: The steer wheels should turn in the direction that the yellow right arrow points on the control panel.
- #### Test Drive and Braking
- 32 Press the drive function select button. The indicator light should turn on.
- 33 Press and hold the function enable switch on the control handle.
- 34 Slowly move the control handle in the direction indicated by the blue arrow on the control panel until the machine begins to move, then return the handle to the center position.
- ⊙ Result: The machine should move in the direction that the blue arrow points on the control panel, then come to an abrupt stop.
- 35 Press and hold the function enable switch on the control handle.
- 36 Slowly move the control handle in the direction indicated by the yellow arrow on the control panel until the machine begins to move, then return the handle to the center position.



## Function Tests

- ⊙ Result: The machine should move in the direction that the yellow arrow points on the control panel, then come to an abrupt stop.

Note: The brakes must be able to hold the machine on any slope it is able to climb.

### Test Limited Drive Speed

- 37 Press and hold the function enable switch. Raise the platform approximately 1.3 m from the ground.

- ⊙ Result: The pothole guards should deploy.

- 38 Press and hold the function enable switch on the control handle.

- 39 Slowly move the control handle to the full drive position.

- ⊙ Result: The maximum achievable drive speed with the platform raised should not exceed 13.8cm/s.

- ⊗ If the drive speed with the platform raised exceeds 13.8 cm/s, immediately tag and remove the machine from service.

### Test the Tilt Sensor Operation

Note: Perform this test from the ground with the platform controller. Do not stand in the platform.

- 40 Fully lower the platform.
- 41 Place a 3×20 cm or similar piece of wood under both wheels on one side and drive the machine up onto them.
- 42 Raise the platform approximately 1.3 m from the ground.
- ⊙ Result: The platform should stop and the tilt alarm will sound at 180 beeps per minute. The platform controls LED readout should display LL.
- 43 Press the drive function select button.
- 44 Press and hold the function enable switch on the control handle.

- 45 Move the control handle in the direction indicated by the blue arrow, then move the control handle in the direction indicated by the yellow arrow.

- ⊙ Result: The drive function should not work in either direction.

- 46 Lower the platform and drive the machine off the block.

### Test the Pothole Guards

Note: The pothole guards should automatically deploy when the platform is raised. The pothole guards activate another limit switch which allows the machine to continue to function. If the pothole guards do not deploy, an alarm sounds and the machine will not drive and lift.

- 47 Raise the platform.

- ⊙ Result: When the platform is raised approximately 1.3 m from the ground, the pothole guards should deploy.

- 48 Press on the pothole guards on one side, and then the other.

- ⊙ Result: The pothole guards should not move.

- 49 Lower the platform.

- ⊙ Result: The pothole guards should return to the stowed position.

- 50 Place a 3×20 cm or similar piece of wood under a pothole guard. Raise the platform.

- ⊙ Result: When the platform is raised approximately 1.3m from the ground, the pothole alarm will sound at 180 beeps per minute, and the platform controls LED screen readout should display 58.

- 51 Press the drive function select button.

- 52 Press and hold the function enable switch on the control handle.

- 53 Move the control handle in the direction

## Function Tests

indicated by the blue arrow, and then move the control handle in the direction indicated by the yellow arrow.

- ⊙ Result: The drive function should not work in either direction.
- 54 Press and hold the function enable switch on the control handle.
- 55 Depress the thumb rocker switch on top of the control handle in the direction identified by the blue and yellow arrow on the control panel.
- ⊙ Result: The steer function should not work in either direction.
- 56 Lower the platform and remove the 3×20 cm wood block.

## Operating Instructions



### Do Not Operate Unless:

- You learn and practice the principles of safe machine operation contained in this operator's manual.
  - 1 Avoid hazardous situations.
  - 2 Always perform a pre-operation inspection.
  - 3 Inspect the workplace.
  - 4 Always perform function tests prior to use.
  - 5 **Only use the machine as it was intended.**

### Fundamentals

This machine is a self-propelled hydraulic lift equipped with a work platform on the scissor mechanism. Vibrations emitted by these machines are not hazardous to an operator in the work platform. The machine can be used to position personnel with their tools and supplies at position above ground level and can be used to reach work areas located above and over machinery or equipment.

The Operating Instructions section provides instructions for each aspect of machine operation.

It is the operator's responsibility to follow all the safety rules and instructions in the operator's manual.

Using the machine for anything other than lifting personnel, along with their tools and materials, to an aerial work site is unsafe and dangerous.

Only trained and authorized personnel should be permitted to operate a machine. If more than one operator is expected to use a machine at different times in the same work shift, they must all be qualified operators and are all expected to follow all safety rules and instructions in the operator's manual. That means every new operator should perform a pre-operation inspection, function tests, and a workplace inspection before using the machine.

## Operating Instructions

### Emergency Stop

Push in the red Emergency Stop button to the off position at the ground controls or the platform controls to stop all machine functions.

Repair any function that operates when either red Emergency Stop button is pushed in.

### Emergency Lowering

- 1 Pull the emergency lowering knob.

### Operation from Ground

- 1 Be sure the battery pack is connected before operating the machine.
- 2 Turn the key switch to ground control.
- 3 Pull out the red Emergency Stop button to the on position at both the ground and platform controls.

#### To Position Platform

- 1 Move the platform up/down switch according to the markings on the control panel.

Drive and steer functions are not available from the ground controls.

### Operation from Platform

- 1 Be sure the battery pack is connected before operating the machine.
- 2 Turn the key switch to platform control.
- 3 Pull out the red Emergency Stop button to the on position at both the ground and platform controls.

#### To Position Platform

- 1 Press the lift function select button.
- 2 Press and hold the function enable switch on the control handle.

- 3 Move the control handle according to the markings on the control panel.

#### To Steer

- 1 Press the drive function select button.
- 2 Press and hold the function enable switch on the control handle.
- 3 Turn the steer wheels with the thumb rocker switch located on the top of the control handle.

#### To Drive

- 1 Press the drive function select button.
- 2 Press and hold the function enable switch on the control handle.
- 3 Increase speed: Slowly move the control handle off center.

Decrease speed: Slowly move the control handle toward center.

Stop: Return the control handle to center or release the function enable switch.

Use the color-coded direction arrows on the platform controls to identify the direction the machine will travel.

Machine travel speed is restricted when the platform is raised.

Battery condition will affect machine performance. Machine drive speed and function speed will drop when the battery level indicator is flashing.

#### To reduce drive speed

The drive controls can operate in two different drive speed modes. When the drive speed button light is on, slow drive speed mode is active. When the button light is off, fast drive speed mode is active.

Press the drive speed button to select the desired drive speed.

## Operating Instructions

### ▲ Driving on a slope

Determine the slope and side slope ratings for the machine and determine the slope grade.

Maximum slope rating, stowed position 25%,

Maximum side slope rating, stowed position 25%.

Note: Slope rating is subject to ground conditions and adequate traction.

Press the drive speed button to the fast drive speed mode.

### To determine the slope grade

Measure the slope with a digital inclinometer OR use the following procedure.

You will need:

Carpenter's level

Straight piece of wood, at least 1 m long

Tape measure

Lay the piece of wood on the slope.

At the downhill end, lay the level on the top edge of the piece of wood and lift the end until the piece of wood is level.

While holding the piece of wood level, measure the distance from the bottom of the piece of wood to the ground.

Divide the tape measure distance (rise) by the length of the piece of wood (run) and multiply by 100.

Example:

Run = 3.6 m

Rise = 0.3 m

$$0.3 \text{ m} \div 3.6 \text{ m} = 0.083 \times 100 = 8.3\%$$

If the slope exceeds the maximum slope or side slope rating, the machine must be winched or transported up or down the slope. See Transport and Lifting section.



### Operation from Ground with Controller

Maintain safe distances between operator, machine and fixed objects.

Be aware of the direction the machine will travel when using the controller.

### Battery Level Indicator



Full

Low

Use the LED readout screen to determine the battery level.

### How to use the Safety Arm

- 1 Raise the platform until the distance of the two sets of scissor at least 0.4m.
- 2 Lift the safety arm, move it to the center of the scissor arm and rotate down to a vertical position.
- 3 Lower the platform until the safety arm rests securely on the link. Keep clear of the safety arm when lowering the platform.

**⚠ DANGER** Don't engage the safety arm unless unload the platform.

### How to Fold Down the Guardrails

The platform railing system consists of three fold down rail section for the extension deck and three sections for the main deck. All sections are held in place by four wire lock pins.

- 1 Fully lower the platform and retract the platform extension.

## Operating Instructions

- 2 Remove the platform controls.
- 3 From inside the platform, remove the two front extension deck wire lock pins.
- 4 Fold down the front rail assembly. Keep hands clear of pinch points.
- 5 Replace the two removed pins back into each side rail bracket.
- 6 Fold down the extension platform left rail assembly. Keep hands clear of pinch points.
- 7 Fold down the extension platform right rail assembly. Keep hands clear of pinch points.
- 8 Carefully open the gate and move to the rear step or the ground.
- 9 From the rear step or from the ground, remove the left rear main deck wire lock pins.
- 10 Fold down the left rail assembly. Keep hands clear of pinch points.
- 11 Replace the removed pin back into rear rail bracket.
- 12 Remove the right rear main deck wire lock pins.
- 13 Fold down the right rail assembly. Keep hands clear of pinch points.
- 14 Replace the removed pin back into rear rail bracket.
- 15 Fold down the rear rail assembly. Keep hands free of pinch points.

## To Extend and Retract Platform

- 1 Press the platform lock pin pedal on the extension deck by foot.
- 2 Push the platform extension guardrail to extend the platform to the desired position.

Do not stand on the platform extension while trying to extend it.

## How to Raise the Guardrails

Follow the fold down instructions but in reverse order.

**Operating Instructions****WARNING CODE DESCRIPTION**

<b>warning code</b>	<b>Warning Description</b>	<b>Denied motion</b>
51	ECU ALARM	ALL
52	PCU ALARM	ALL
53	TM1 ALARM	ALL
54	PRESS SENSOR ERROR	ALL
55	LOCK TRACTION IF CAGE UP	Machine traction & steering (cage-up traction speed must be 0)
56	LEVEL SENSOR ERROR	cage lifting
OL	MACHINE OVERLOAD	cage lifting & vehicle traction
58	POTHOLE SWITCH FAULT	cage lifting & vehicle traction
59	HIGH POSTION LIMIT	cage lifting
60	OUTDOOR 2.5M HEIGHT LIMIT	cage lifting
61	LOW POSITION LIMIT	Cage descent
62	TILT CYLIDER OUT	cage steering & vehicle traction
LL	TILTING X OVER THRESHOLD	cage lifting & vehicle traction
LL	TILTING Y OVER THRESHOLD	cage lifting & vehicle traction
63	ANTI-HAND CLAMP STOP	Cage descent. to release joystick or toggle switch and redo the motion
64	CAGE NOT ALLOWED EXTENDED	Cage platform extension
65	CAGE EXTENDED	Cage descent.
66	LOW BATTERY LEVEL	Cage lifting, turtle/rabbit speed traction. "cage-up" speed traction is allowed
67	OBSTACLE UNDER CAGE	Cage descent
68	CAGE DOOR OPEN	cage lifting & vehicle traction
70	POTHOLE SWITCH FAULT	cage lifting & vehicle traction
71	CAGE SIDE OPEN	vehicle traction
72	CHAIN LOOSE	vehicle traction & cage descent
73	FRONT RADAR	vehicle traction
74	ANTI COLLISION	Cage lifting (for scissor only)
75	Rental Locked	

## Operating Instructions

<b>warning code</b>	<b>Warning Description</b>	<b>Denied motion</b>
76	GPS LOCKER	
80	RenewRental 1 month	
81	RenewRental 3 month	
82	RenewRental 6 month	
83	RenewRental 12 month	
88	TRACTION MOTOR RIGHT SIDE OVERLOAD	NONE. Warning only
89	TRACTION MOTOR LEFT SIDE OVERLOAD	NONE. Warning only
90	TM1 PCB HIGH TEMPERATURE	NONE. Warning only
91	TM1 RADIATOR HIGH TEMPERATURE	NONE. Warning only
92	TM1 PARAMETER OVER LIMIT	NONE. Warning only
93	TM has not software parameters	NONE. Warning only
94	PUMP MOTOR OVERLOAD	NONE. Warning only
95	EMPTY CALIBRATION FAULT	NONE. Warning only
96	LADEN CALIBRATION FAULT	NONE. Warning only
97	CAGE LIFTING FUNCTION IS OVERRIDED	NONE. Warning only
98	VEHICLE BRAKE RELEASED	NONE. Warning only
99	VEHICLE BYPASS FUNCTION ENGAGED	NONE. Warning only



**Operating Instructions****ALARM CODE DESCRIPTION**

<b>Alarm code</b>	<b>Alarm Description</b>	<b>Denied motion</b>
101	ECU E2PROM ALARM	ALL
102	ECU WATCHDOG FAULT	ALL
103	LMI OverLoad_Start	
104	ECU Thermal Calib.	
105	Init. Data Logger	
106	E2P Save On Err	
107	TMPParameter Modified	
108	Password Inserted	
109	LMI OverLoad_End	
110	PCU CPU0 CANBUS TIMEOUT1	ALL
111	PCU CPU0 CANBUS TIMEOUT2	ALL
112	PCU CPU1 CANBUS TIMEOUT1	ALL
113	PCU CPU1 CANBUS TIMEOUT2	ALL
114	TM1 CANBUS TIMEOUT	ALL
116	PRESSURE SENSOR REDUNDANT CHECK FAULT	ALL
117	ANALOG SCISSOR ANGLE SENSOR REDUNDANT CHECK FAULT	ALL
118	TILT-X REDUNDANT CHECK FAULT	ALL
119	TILT-Y REDUNDANT CHECK FAULT	ALL
120	KEY SWITCH INPUT CHECK FAULT	ALL
121	TOGGLE SWITCH INPUT CHECK FAULT	ALL
122	ECU PIN29, INP00 REDUNDANT CHECK FAULT	ALL
123	ECU PIN30, INP01 REDUNDANT CHECK FAULT	ALL
124	ECU PIN32, INP02 REDUNDANT CHECK FAULT	ALL
125	ECU PIN33, INP03 REDUNDANT CHECK FAULT	ALL
126	ECU PIN06, INP04 REDUNDANT CHECK FAULT	ALL
127	ECU PIN34, INP05 REDUNDANT CHECK FAULT	ALL
128	ECU PIN45, INP10 REDUNDANT CHECK FAULT	ALL
129	ECU PIN46, INP11 REDUNDANT CHECK FAULT	ALL
130	ECU PIN47, INP12 REDUNDANT CHECK FAULT	ALL

## Operating Instructions

Alarm code	Alarm Description	Denied motion
131	ECU PIN48, INP13 REDUNDANT CHECK FAULT	ALL
132	ECU PIN49, INP14 REDUNDANT CHECK FAULT	ALL
133	ECU PIN50, INP15 REDUNDANT CHECK FAULT	ALL
134	ECU PIN19, INP RELAY REDUNDANT CHECK FAULT	ALL
135	ECU PIN20, INP BRAKE REDUNDANT CHECK FAULT	ALL
136	ECU PIN23, INP M1 REDUNDANT CHECK FAULT	ALL
137	ECU PIN24, INP M2 REDUNDANT CHECK FAULT	ALL
138	PRESSURE SENSOR N.1 OPEN CIRCUIT OR SHORT TO GND	ALL
139	PRESSURE SENSOR N.1 SHORT CIRCUIT TO PWR	ALL
140	PRESSURE SENSOR N.1 VALUE LOWER THAN THRESHOLD MIN.	ALL
141	PRESSURE SENSOR N.1 VALUE GREATER THAN THRESHOLD MAX.	ALL
142	PRESSURE SENSOR N.2 OPEN CIRCUIT OR SHORT TO GND	ALL
143	PRESSURE SENSOR N.2 SHORT CIRCUIT TO PWR	ALL
144	PRESSURE SENSOR N.2 VALUE LOWER THAN THRESHOLD MIN.	ALL
145	PRESSURE SENSOR N.2 VALUE GREATER THAN THRESHOLD MAX.	ALL
146	ANALOG SCISSOR ANGLE CHANNEL A: OPEN CIRCUIT OR SHORT TO GND	ALL
147	ANALOG SCISSOR ANGLE CHANNEL A: SHORT CIRCUIT TO PWR	ALL
148	ANALOG SCISSOR ANGLE CHANNEL A: ANGLE VALUE LOWER THAN MIN.	ALL
149	ANALOG SCISSOR ANGLE CHANNEL A: ANGLE VALUE GREATER THAN MAX.	ALL
150	ANALOG SCISSOR ANGLE CHANNEL B: OPEN CIRCUIT OR SHORT TO GND	ALL
151	ANALOG SCISSOR ANGLE CHANNEL B: SHORT CIRCUIT TO PWR	ALL
152	ANALOG SCISSOR ANGLE CHANNEL B: ANGLE VALUE LOWER THAN MIN.	ALL
153	ANALOG SCISSOR ANGLE CHANNEL B: ANGLE VALUE GREATER THAN MAX.	ALL
154	.ADXL Open Circuit	ALL
160	ECU PIN01 OUT00 SHORT TO +VB	ALL
161	ECU PIN01 OUT00 INTERNAL FAULT	ALL
162	ECU PIN01 OUT00 CHECK FAULT	ALL

**Operating Instructions**

<b>Alarm code</b>	<b>Alarm Description</b>	<b>Denied motion</b>
163	ECU PIN01 OUT00 OPEN CIRCUIT	ALL
164	ECU PIN01 OUT00 SHORT CIRCUIT	ALL
165	ECU PIN02 OUT01 SHORT TO +VB	ALL
166	ECU PIN02 OUT01 INTERNAL FAULT	ALL
167	ECU PIN02 OUT01 CHECK FAULT	ALL
168	ECU PIN02 OUT01 OPEN CIRCUIT	ALL
169	ECU PIN02 OUT01 SHORT CIRCUIT	ALL
170	ECU PIN04 OUT02 SHORT TO +VB	ALL
171	ECU PIN04 OUT02 INTERNAL FAULT	ALL
172	ECU PIN04 OUT02 CHECK FAULT	ALL
173	ECU PIN04 OUT02 OPEN CIRCUIT	ALL
174	ECU PIN04 OUT02 SHORT CIRCUIT	ALL
175	ECU PIN05 OUT03 SHORT TO +VB	ALL
176	ECU PIN05 OUT03 INTERNAL FAULT	ALL
177	ECU PIN05 OUT03 CHECK FAULT	ALL
178	ECU PIN05 OUT03 OPEN CIRCUIT	ALL
179	ECU PIN05 OUT03 SHORT CIRCUIT	ALL
180	ECU PIN08 OUT04 SHORT TO +VB	ALL
181	ECU PIN08 OUT04 INTERNAL FAULT	ALL
182	ECU PIN08 OUT04 CHECK FAULT	ALL
183	ECU PIN08 OUT04 OPEN CIRCUIT	ALL
184	ECU PIN08 OUT04 SHORT CIRCUIT	ALL
185	ECU PIN09 OUT05 SHORT TO +VB	ALL
186	ECU PIN09 OUT05 INTERNAL FAULT	ALL
187	ECU PIN09 OUT05 CHECK FAULT	ALL
188	ECU PIN09 OUT05 OPEN CIRCUIT	ALL
189	ECU PIN09 OUT05 SHORT CIRCUIT	ALL
190	ECU PIN11 OUT06 SHORT TO +VB	ALL
191	ECU PIN11 OUT06 INTERNAL FAULT	ALL
192	ECU PIN11 OUT06 CHECK FAULT	ALL

## Operating Instructions

<b>Alarm code</b>	<b>Alarm Description</b>	<b>Denied motion</b>
193	ECU PIN11 OUT06 OPEN CIRCUIT	ALL
194	ECU PIN11 OUT06 SHORT CIRCUIT	ALL
195	ECU PIN13 OUT07 SHORT TO +VB	ALL
196	ECU PIN13 OUT07 INTERNAL FAULT	ALL
197	ECU PIN13 OUT07 CHECK FAULT	ALL
198	ECU PIN13 OUT07 OPEN CIRCUIT	ALL
199	ECU PIN17 OUT07 SHORT CIRCUIT	ALL
200		
201	Pump Current Offset error	ALL
202	Traction motor 1 Current Offset error	ALL
203	Traction motor 2 Current Offset error	ALL
204	TM1 HW Parameter Loading error	ALL
205	TM1 Parameter Loading error	ALL
210	TM Power Over Range	ALL
211	TM Power Relay Stuck	ALL
212	TM Precharge Undone	ALL
213	TM Power Relay Open	ALL
214	Traction motor1 Short Circuit	ALL
215	Traction motor2 Short Circuit	ALL
216	Pump Short Circuit	ALL
217	Excitation circuit in short circuit (for TM2 SepEx. only)	ALL
220	Pump Over Current	ALL
221	Traction motor1 Over Current	ALL
222	Traction motor2 Over Current	ALL
223	TM Capacitor Over Voltage	ALL
224	TM Capacitor Low Voltage	ALL
225	TM PCB high temperature alarm	ALL
226	TM Radiator high temperature alarm	ALL
227	TM OUT1 Over Current	ALL
228	TM OUT2 Over Current	ALL

**Operating Instructions**

<b>Alarm code</b>	<b>Alarm Description</b>	<b>Denied motion</b>
229	TM OUT3 Over Current	ALL
230	TM WatchDog Error	ALL
231	TM WatchDog Validity Error	ALL
232	TM Pump Open Circuit	ALL
233	Tractor Motor1 Open circuit	ALL
234	Tractor Motor2 Open circuit	ALL
235	Traction Motor1 Wiring Error	ALL
236	Traction Motor2 Wiring Error	ALL
237	TM Excitation Open Circuit	ALL
238	TM Excitation Wiring Error	ALL
239	Vehicle Battery Under Voltage	ALL
240	Excitation circuit over current (for TM2 SepEx. only)	ALL
241	Field Open Circuit (After Reboot)	ALL
260	Tilt OverLimit_start	
261	Tilt OverLimit_end	
262	Batt.Charging Start	
263	Batt.Charging End	
280	AL_PCU_INITCHECK	
281	PCU cpu0 fault	ALL
282	PCU cpu1 fault	ALL
300	ECU OUT08 SHORT TO +VB	ALL
301	ECU OUT08 INTERNAL FAULT	ALL
302	ECU OUT08 CHECK FAULT	ALL
303	ECU OUT08 OPEN CIRCUIT	ALL
304	ECU OUT08 SHORT CIRCUIT	ALL
305	ECU OUT09 SHORT TO +VB	ALL
306	ECU OUT09 INTERNAL FAULT	ALL
307	ECU OUT09 CHECK FAULT	ALL
308	ECU OUT09 OPEN CIRCUIT	ALL
309	ECU OUT09 SHORT CIRCUIT	ALL

## Operating Instructions

<b>Alarm code</b>	<b>Alarm Description</b>	<b>Denied motion</b>
310	ECU OUT10 SHORT TO +VB	ALL
311	ECU OUT10 INTERNAL FAULT	ALL
312	ECU OUT10 CHECK FAULT	ALL
313	ECU OUT10 OPEN CIRCUIT	ALL
314	ECU OUT10 SHORT CIRCUIT	ALL
315	ECU RELAY OUTPUT SHORT TO +VB	ALL
316	ECU RELAY OUTPUT INTERNAL FAULT	ALL
317	ECU RELAY OUTPUT CHECK FAULT	ALL
318	ECU RELAY OUTPUT OPEN CIRCUIT	ALL
319	ECU RELAY OUTPUT SHORT CIRCUIT	ALL
320	ECU OUTPUT BRAKE1 SHORT TO +VB	ALL
321	ECU OUTPUT BRAKE1 INTERNAL FAULT	ALL
322	ECU OUTPUT BRAKE1 CHECK FAULT	ALL
323	ECU OUTPUT BRAKE1 OPEN CIRCUIT	ALL
324	ECU OUTPUT BRAKE1 SHORT CIRCUIT	ALL
325	ECU OUTPUT BRAKE2 P SHORT TO +VB	ALL
326	ECU OUTPUT BRAKE2 INTERNAL FAULT	ALL
327	ECU OUTPUT BRAKE2 CHECK FAULT	ALL
328	ECU OUTPUT BRAKE2 OPEN CIRCUIT	ALL
329	ECU OUTPUT BRAKE2 SHORT CIRCUIT	ALL

**Operating Instructions****Troubleshooting chart**

<b>Code</b>	<b>Possible failure reason</b>	<b>Suggested operation</b>
OL	Vehicle is overloaded	Reduce the vehicle load
LL	The vehicle tilting level is greater than the threshold setting.	Bring the vehicle to leveled ground, or to descend the platform to minimum position
	If you are certain the ground is well leveled	Check the system or to calibrate the ECU tilting sensor (see the sensor calibration chapter)
51	System failures	Refer to the alarm code description for detailed information
52	Joystick PCU failure	Refer to the alarm code description for detailed information
53	TM traction module failures	Refer to the alarm code description for detailed information
54	Pressure transducer failures	Refer to the alarm code description for detailed information
55	“Traction Lock” input is high level therefore the traction function is cut off	Descend the platform in order to unlock traction function
	“Traction Lock” input is short circuited	Check the “traction lock” switch
58	When the platform is off minimum position, the pothole switch is still “low-level” signal.	Check the pothole switch electric signal
	When the platform is off minimum position, the pothole mechanical system is stuck.	Check the pothole mechanical system
59	The platform reaches the maximum position	Descend the platform
	The max. position micro switch is open circuit (if applicable)	Check the max. position micro switch (if applicable)
60	Outdoor 2.5mt height limit function	Turn off the “outdoor 2.5mt height” function or to descend the platform
	“Outdoor 2.5mt height “ micro switch is open circuit	Check the micro switch
61	The platform reaches the lowest position	Lifting the platform
62	Rear axle leveling limit switch activation	reset the cylinder
63	the platform stops descending for “anti-hand-clamp” purpose	Release the joystick or toggle switch, then operate again for platform descent
64	Platform extended at the height of “anti-hand-clamp”	reset the platform
65	Platform extended and fall to the height of “anti-hand-clamp”	reset the platform
66	Low battery level ( less than 15% )	Recharge the vehicle battery
	Wrong battery level calculation	Recharge the vehicle and reset the system power

## Operating Instructions

Code	Possible failure reason	Suggested operation
67	There is obstacle under the vehicle platform	Remove the obstacle
	“ultrasonic” input failure	Check the ultrasonic sensor
68	The platform safety door is open	Close the platform safety door
	Platform safety door switch failure	Check the safety door micro switch
70	When the platform is at minimum position, the pothole switch is “high level” signal	Check the pothole switch electric signal
	When the platform is at minimum position, the pothole mechanical system does not retract	Check the pothole mechanical system
71	The platform lateral extension is not retracted	Retract the platform lateral extension
	The platform lateral extension micro switch failure	Check the micro switch
72	The platform chain is loosed (if applicable)	Check the chain
	The platform chain micro switch is short circuited	Check the micro switch
73	There is obstacle in front of the vehicle	Remove the obstacle
	Vehicle “front radar” sensor is short circuited	Check the sensor
74	Vehicle “anti-collision” input has “high level” signal	Check your working surrounding and regulate the position of platform
	The “anti collision” switch is short circuited	Check the micro switch
88	Traction motor right side is in overload	-- Stop vehicle translation and control the wheel status; -- Vehicle is probably travel on abrupt ramp uphill. Stop vehicle periodically for cooling down the motor.
89	Traction motor left side is in overload	-- Stop vehicle translation and control the wheel status; -- Vehicle is probably travel on abrupt ramp uphill. Stop vehicle periodically for cooling down the motor.
90	Traction module internal temperature is high	Stop using the vehicle and cool down the traction module
	The working surrounding of vehicle is too hot	Change the working location or reduce the location temperature
91	Traction module internal temperature is high	Stop using the vehicle and cool down the traction module
	The working surrounding of vehicle is too hot	Change the working location or reduce the location temperature
	Wrong installation of the TM radiator	Check the TM radiator installation
92	There is at least 1 TM parameter is out of the allowed range	Contact the assistance for checking the TM parameter setting



**Operating Instructions**

<b>Code</b>	<b>Possible failure reason</b>	<b>Suggested operation</b>
94	Pump motor is in overload	There is too much load in the cage. Reduce the weight.
95	The empty load calibration of LMI function does not finish successfully	Redo the empty load calibration
96	The laden load calibration of LMI function does not finish successfully	Redo the empty load calibration
97	The cage lifting stop is override. It won't stop until reach the cylinder end of stroke.	Pay attention when use this function.
98	The vehicle traction brake is manually released	To engage the vehicle brake, cycle the system power
99	The vehicle bypass (override) function is engaged	To disengage the function, cycle the system power
101	ECU SW is updated	Go to the operation menu and execute "saving" procedure
	ECU internal failure	Contact assistance, or replace ECU unit
102	ECU watchdog check failure	Check the harness and ECU connection
	ECU internal failure	Contact assistance, or replace ECU unit
110	Joystick PCU CAN bus communication failure	Check the harness and connection, or replace the PCU unit
111	Joystick PCU CAN bus communication failure	Check the harness and connection, or replace the PCU unit
112	Joystick PCU CAN bus communication failure	Check the harness and connection, or replace the PCU unit
113	Joystick PCU CAN bus communication failure	Check the harness and connection, or replace the PCU unit
114	Traction module TM CAN bus communication failure	Check the harness and connection, or replace the TM unit
116	Pressure difference between pressure transducer n.1 & n.2 is greater than allowed tolerance (if applicable)	Check the harness and connection
	Pressure transducer n.1 failure	Replace pressure transducer
	Pressure transducer n.1 failure (if applicable)	Replace pressure transducer
117	Scissor angle potentiometer has redundant signal failure (if applicable)	Check the harness and connection
	Scissor angle potentiometer open circuit / short circuit	Check the harness and connection, or replace potentiometer
	Scissor angle potentiometer internal failure	Replace potentiometer
118	ECU Tilt sensor X axis value failure	Redo vehicle 0° level calibration
	ECU tilt sensor internal failure	Replace ECU, or redo vehicle 0° level calibration

## Operating Instructions

<b>Code</b>	<b>Possible failure reason</b>	<b>Suggested operation</b>
119	ECU Tilt sensor Y axis value failure	Redo vehicle 0° level calibration
	ECU tilt sensor internal failure	Replace ECU, or redo vehicle 0° level calibration
120	ECU key switch failure	Check the ECU key switch signal (diagnostic screen)
	ECU internal failure	Contact assistance, or replace ECU
121	ECU toggle switch failure	Check the ECU toggle switch signal (diagnostic screen)
	ECU internal failure	Contact assistance, or replace ECU
122	ECU pin n.29 (IN 00) failure	Contact assistance, or replace ECU
	ECU internal failure	Contact assistance, or replace ECU
123	ECU pin n.30 (IN 01) failure	Contact assistance, or replace ECU
	ECU internal failure	Contact assistance, or replace ECU
124	ECU pin n.32 (IN 02) failure	Contact assistance, or replace ECU
	ECU internal failure	Contact assistance, or replace ECU
125	ECU pin n.33 (IN 03) failure	Contact assistance, or replace ECU
	ECU internal failure	Contact assistance, or replace ECU
126	ECU pin n.06 (IN 04) failure	Contact assistance, or replace ECU
	ECU internal failure	Contact assistance, or replace ECU
127	ECU pin n.34 (IN 05) failure	Contact assistance, or replace ECU
	ECU internal failure	Contact assistance, or replace ECU
128	ECU pin n.45 (IN 10) failure	Contact assistance, or replace ECU
	ECU internal failure	Contact assistance, or replace ECU
129	ECU pin n.46 (IN 11) failure	Contact assistance, or replace ECU
	ECU internal failure	Contact assistance, or replace ECU
130	ECU pin n.47 (IN 12) failure	Contact assistance, or replace ECU
	ECU internal failure	Contact assistance, or replace ECU
131	ECU pin n.48 (IN 13) failure	Contact assistance, or replace ECU
	ECU internal failure	Contact assistance, or replace ECU
132	ECU pin n.49 (IN 14) failure	Contact assistance, or replace ECU
	ECU internal failure	Contact assistance, or replace ECU
133	ECU pin n.19 (IN RELAY) failure	Contact assistance, or replace ECU
	ECU internal failure	Contact assistance, or replace ECU

**Operating Instructions**

<b>Code</b>	<b>Possible failure reason</b>	<b>Suggested operation</b>
134	ECU pin n.20 (IN BRAKE) failure	Contact assistance, or replace ECU
	ECU internal failure	Contact assistance, or replace ECU
135	ECU pin n.23 (IN M1) failure	Contact assistance, or replace ECU
	ECU internal failure	Contact assistance, or replace ECU
136	ECU pin n.24 (IN M2) failure	Contact assistance, or replace ECU
	ECU internal failure	Contact assistance, or replace ECU
137	ECU pin n.29 (IN 00) failure	Contact assistance, or replace ECU
	ECU internal failure	Contact assistance, or replace ECU
138	Pressure transducer n.1 open circuit	Check harness and connection
	Pressure transducer n.1 internal failure	Replace pressure transducer
139	Pressure transducer n.1 short circuit	Check harness and connection
	Pressure transducer n.1 internal failure	Replace pressure transducer
140	Pressure transducer n.1 has low pressure value	Contact assistance, check the pressure transducer parameter setting
141	Pressure transducer n.1 has high pressure value	Contact assistance, check the pressure transducer parameter setting
	Pressure transducer n.1 internal failure	Replace pressure transducer
142	Pressure transducer n.2 open circuit (if applicable)	Check harness and connection
	Pressure transducer n.2 internal failure (if applicable)	Replace pressure transducer
143	Pressure transducer n.2 short circuit (if applicable)	Check harness and connection
	Pressure transducer n.2 internal failure (if applicable)	Replace pressure transducer
144	Pressure transducer n.2 has low pressure value (if applicable)	Contact assistance, check the pressure transducer parameter setting
145	Pressure transducer n.2 has high pressure value (if applicable)	Contact assistance, check the pressure transducer parameter setting
	Pressure transducer n.2 internal failure (if applicable)	Replace pressure transducer
146	Scissor angle potentiometer n.1 open circuit	Check harness and connection
	Scissor angle potentiometer n.1 internal failure	Replace potentiometer
147	Scissor angle potentiometer n.1 short circuit	Check harness and connection
	Scissor angle potentiometer n.1 internal failure	Replace potentiometer

## Operating Instructions

Code	Possible failure reason	Suggested operation
148	Scissor angle potentiometer n.1 converted value too low	Contact assistance, check the potentiometer parameter setting
149	Scissor angle potentiometer n.1 converted value too high	Contact assistance, check the potentiometer parameter setting
	Scissor angle potentiometer n.1 internal failure	Replace potentiometer
150	Scissor angle potentiometer n.1 open circuit	Check harness and connection
	Scissor angle potentiometer n.1 internal failure	Replace potentiometer
151	Scissor angle potentiometer n.1 short circuit	Check harness and connection
	Scissor angle potentiometer n.1 internal failure	Replace potentiometer
152	Scissor angle potentiometer n.1 converted value too low	Contact assistance, check the potentiometer parameter setting
153	Scissor angle potentiometer n.1 converted value too high	Contact assistance, check the potentiometer parameter setting
	Scissor angle potentiometer n.1 internal failure	Replace potentiometer
160	ECU pin n.01 (OUT 00) is short to power +VB	Check harness and connection
	ECU internal failure	Contact assistance, or replace ECU unit
161	ECU pin n.01 (OUT 00) internal failure	Contact assistance, or replace ECU unit
	ECU internal failure	Contact assistance, or replace ECU unit
162	ECU watchdog failure ( internal short circuit )	replace ECU unit
	ECU internal failure	Contact assistance, or replace ECU unit
163	ECU pin n.01 (OUT 00): external load is open circuit	Check harness and connection
	ECU internal failure	Contact assistance, or replace ECU unit
164	ECU pin n.01 (OUT 00): external load is short circuit	Check harness and connection
	ECU internal failure	Contact assistance, or replace ECU unit
165	ECU pin n.02(OUT 01) is short to power +VB	Check harness and connection
	ECU internal failure	Contact assistance, or replace ECU unit
166	ECU pin n.02 (OUT 01) internal failure	Contact assistance, or replace ECU unit
	ECU internal failure	Contact assistance, or replace ECU unit
167	ECU watchdog failure ( internal short circuit )	replace ECU unit
	ECU internal failure	Contact assistance, or replace ECU unit

**Operating Instructions**

<b>Code</b>	<b>Possible failure reason</b>	<b>Suggested operation</b>
168	ECU pin n.02 (OUT 01): external load is open circuit	Check harness and connection
	ECU internal failure	Contact assistance, or replace ECU unit
169	ECU pin n.02 (OUT 01): external load is short circuit	Check harness and connection
	ECU internal failure	Contact assistance, or replace ECU unit
170	ECU pin n.04(OUT 02) is short to power +VB	Check harness and connection
	ECU internal failure	Contact assistance, or replace ECU unit
171	ECU pin n.04 (OUT 02) internal failure	Contact assistance, or replace ECU unit
	ECU internal failure	Contact assistance, or replace ECU unit
172	ECU watchdog failure ( internal short circuit )	replace ECU unit
	ECU internal failure	Contact assistance, or replace ECU unit
173	ECU pin n.04 (OUT 02): external load is open circuit	Check harness and connection
	ECU internal failure	Contact assistance, or replace ECU unit
174	ECU pin n.04 (OUT 02): external load is short circuit	Check harness and connection
	ECU internal failure	Contact assistance, or replace ECU unit
175	ECU pin n.05(OUT 03) is short to power +VB	Check harness and connection
	ECU internal failure	Contact assistance, or replace ECU unit
176	ECU pin n.05 (OUT 03) internal failure	Contact assistance, or replace ECU unit
	ECU internal failure	Contact assistance, or replace ECU unit
177	ECU watchdog failure ( internal short circuit )	replace ECU unit
	ECU internal failure	Contact assistance, or replace ECU unit
178	ECU pin n.05 (OUT 03): external load is open circuit	Check harness and connection
	ECU internal failure	Contact assistance, or replace ECU unit
179	ECU pin n.05 (OUT 03): external load is short circuit	Check harness and connection
	ECU internal failure	Contact assistance, or replace ECU unit
180	ECU pin n.08(OUT 04) is short to power +VB	Check harness and connection
	ECU internal failure	Contact assistance, or replace ECU unit
181	ECU pin n.08 (OUT 04) internal failure	Contact assistance, or replace ECU unit
	ECU internal failure	Contact assistance, or replace ECU unit

## Operating Instructions

Code	Possible failure reason	Suggested operation
182	ECU watchdog failure ( internal short circuit )	replace ECU unit
	ECU internal failure	Contact assistance, or replace ECU unit
183	ECU pin n.08 (OUT 04): external load is open circuit	Check harness and connection
	ECU internal failure	Contact assistance, or replace ECU unit
184	ECU pin n.08 (OUT 04): external load is short circuit	Check harness and connection
	ECU internal failure	Contact assistance, or replace ECU unit
185	ECU pin n.09(OUT 05) is short to power +VB	Check harness and connection
	ECU internal failure	Contact assistance, or replace ECU unit
186	ECU pin n.09 (OUT 05) internal failure	Contact assistance, or replace ECU unit
	ECU internal failure	Contact assistance, or replace ECU unit
187	ECU watchdog failure ( internal short circuit )	replace ECU unit
	ECU internal failure	Contact assistance, or replace ECU unit
188	ECU pin n.09 (OUT 05): external load is open circuit	Check harness and connection
	ECU internal failure	Contact assistance, or replace ECU unit
189	ECU pin n.09 (OUT 05): external load is short circuit	Check harness and connection
	ECU internal failure	Contact assistance, or replace ECU unit
190	ECU pin n.11(OUT 06) is short to power +VB	Check harness and connection
	ECU internal failure	Contact assistance, or replace ECU unit
191	ECU pin n.11 (OUT 06) internal failure	Contact assistance, or replace ECU unit
	ECU internal failure	Contact assistance, or replace ECU unit
192	ECU watchdog failure ( internal short circuit )	replace ECU unit
	ECU internal failure	Contact assistance, or replace ECU unit
193	ECU pin n.11 (OUT 06): external load is open circuit	Check harness and connection
	ECU internal failure	Contact assistance, or replace ECU unit
194	ECU pin n.11 (OUT 06): external load is short circuit	Check harness and connection
	ECU internal failure	Contact assistance, or replace ECU unit
195	ECU pin n.13(OUT 07) is short to power +VB	Check harness and connection
	ECU internal failure	Contact assistance, or replace ECU unit

**Operating Instructions**

<b>Code</b>	<b>Possible failure reason</b>	<b>Suggested operation</b>
196	ECU pin n.13 (OUT 07) internal failure	Contact assistance, or replace ECU unit
	ECU internal failure	Contact assistance, or replace ECU unit
197	ECU watchdog failure ( internal short circuit )	replace ECU unit
	ECU internal failure	Contact assistance, or replace ECU unit
198	ECU pin n.13 (OUT 07): external load is open circuit	Check harness and connection
	ECU internal failure	Contact assistance, or replace ECU unit
199	ECU pin n.13 (OUT 07): external load is short circuit	Check harness and connection
	ECU internal failure	Contact assistance, or replace ECU unit
201	Traction module TM internal failure	Replace TM unit
202	Traction module TM internal failure	Replace TM unit
203	Traction module TM internal failure	Replace TM unit
204	Traction module TM internal chip EEPROM failure	Replace TM unit
	Traction module TM internal failure	Replace TM unit
205	Traction module TM internal chip EEPROM failure	Replace TM unit
	Traction module TM internal failure	Replace TM unit
210	Vehicle battery failure	Check the battery voltage, or replace the vehicle battery
	Battery charger is not disconnected when power on the system	Check the battery charger
	Low battery voltage	Charge the battery, or replace the battery
211	Main power contactor is stuck	Check or replace the main power contactor
	"+Batt" of TM connected to battery "+" side	Check harness and connection
212	Low battery voltage	Charge the battery, or replace the battery
	"+Batt" of TM short to "-Batt" of TM	Check harness and connection
	Traction module TM internal failure	Replace TM unit
213	Main power contactor is open circuit	Check harness and connection, check the ECU output to main contactor
	Main power contactor coil failure	Replace main power contactor
	No power supply to the main power contactor	Check harness and connection

## Operating Instructions

Code	Possible failure reason	Suggested operation
214	M1(right side) traction motor harness short circuit	Check harness and connection
	M1(right side) traction motor internal short circuit	Replace traction motor
	Wrong TM1 parameter setting	Check TM parameter "Trac. Short R. Setting"
215	M2(left side) traction motor harness short circuit	Check harness and connection
	M2(left side) traction motor internal short circuit	Replace traction motor
	Wrong TM1 parameter setting	Check TM parameter "Trac. Short R. Setting"
216	Pump motor harness short circuit	Check harness and connection
	Pump motor internal short circuit	Replace traction motor
	Wrong TM1 parameter setting	Check TM parameter "Pump Short R. Setting"
217	Traction motor harness in short circuit	Check harness and motor connection;
	TM2 hardware failure	Replace TM;
220	Pump motor overload	Check the pump load, harness, connection & hydraulic system
	Pump motor failure	Replace pump motor
	TM internal failure	Replace TM
221	M1(right side) traction motor overload	Check the traction motor load, harness, connection
	traction motor failure	Replace traction motor
	TM internal failure	Replace TM
222	M2(left side) traction motor overload	Check the traction motor load, harness, connection
	traction motor failure	Replace traction motor
	TM internal failure	Replace TM
223	Capacitor group of TM is over voltage	Check harness, connection, replace vehicle battery or TM
	Vehicle brakes roughly	
224	Capacitor group of TM is under voltage	Check harness, connection, replace vehicle battery or TM
	The main power contactor is open circuit	Check the main contactor or ECU, check harness/connection



**Operating Instructions**

<b>Code</b>	<b>Possible failure reason</b>	<b>Suggested operation</b>
225	Traction module internal temperature is high	Stop using the vehicle and cool down the traction module
	The working surrounding of vehicle is too hot	Change the working location or reduce the location temperature
	TM internal failure	Replace TM
226	Traction module internal temperature is high	Stop using the vehicle and cool down the traction module
	The working surrounding of vehicle is too hot	Change the working location or reduce the location temperature
	Wrong installation of the TM radiator	Check the TM radiator installation
227	External load is too high	Check the external load and harness
	The pin out1 of TM is short to GND	Check harness and connection
228	External load is too high	Check the external load and harness
	The pin out2 of TM is short to GND	Check harness and connection
229	External load is too high	Check the external load and harness
	The pin out3 of TM is short to GND	Check harness and connection
230	TM or ECU CAN bus communication failure	Check harness and connection, check CAN line terminal resistance, check ECU
	TM internal failure	Replace TM
231	TM or ECU CAN bus communication failure	Check harness and connection, check CAN line terminal resistance, check ECU
	ECU internal failure	Replace ECU
232	Pump motor is not connected, or harness is open circuit	Check harness and connection
	Pump motor is connected to "-Pump" and "-Batt" of TM	Check the connection drawing
	Wrong pump motor connection	Check connection
233	M1 motor is not connected, or harness is open circuit	Check harness and connection
	TM internal failure	Replace TM
234	M2 motor is not connected, or harness is open circuit	Check harness and connection
	TM internal failure	Replace TM
235	Connection error of M1 traction motor	Check harness and connection
	TM internal failure	Replace TM
236	Connection error of M2 traction motor	Check harness and connection
	TM internal failure	Replace TM

## Operating Instructions

Code	Possible failure reason	Suggested operation
237	In the excitation circuit, there is no traction motor connected or traction motor is open circuit [valid for Separate Excitation TM only]	Check traction motor connection, check harness
	Defective TM	Replace TM
238	Wrong excitation circuit connection: [valid for Separate Excitation TM only]	Check the TM and motor connection
	Defective TM	Replace TM
239	Low battery voltage	Charge the vehicle battery
	Battery terminal is oxidized or corrupted	Replace battery, or harness
240	Excessive load in the excitation circuit	Stop the vehicle for cooling down the motor. If alarm persist, contact assistance;
	Traction motor has issue in excitation circuit	Check traction motor or replace motor
	TM2 internal failure	Replace TM2;
281	CAN bus failure	Cycle the system power
	Joystick PCU failure	Replace PCU
282	CAN bus failure	Cycle the system power
	Joystick PCU failure	Replace PCU
300	ECU pin n.17(OUT 08) is short to power +VB	Check harness and connection
	ECU internal failure	Contact assistance, or replace ECU unit
301	ECU pin n.17 (OUT 08) internal failure	Contact assistance, or replace ECU unit
	ECU internal failure	Contact assistance, or replace ECU unit
302	ECU watchdog failure ( internal short circuit )	replace ECU unit
	ECU internal failure	Contact assistance, or replace ECU unit
303	ECU pin n.17 (OUT 08): external load is open circuit	Check harness and connection
	ECU internal failure	Contact assistance, or replace ECU unit
304	ECU pin n.17 (OUT 08): external load is short circuit	Check harness and connection
	ECU internal failure	Contact assistance, or replace ECU unit
305	ECU pin n.18(OUT 09) is short to power +VB	Check harness and connection
	ECU internal failure	Contact assistance, or replace ECU unit
306	ECU pin n.18 (OUT 09) internal failure	Contact assistance, or replace ECU unit
	ECU internal failure	Contact assistance, or replace ECU unit

**Operating Instructions**

<b>Code</b>	<b>Possible failure reason</b>	<b>Suggested operation</b>
307	ECU watchdog failure ( internal short circuit )	replace ECU unit
	ECU internal failure	Contact assistance, or replace ECU unit
308	ECU pin n.18 (OUT 09): external load is open circuit	Check harness and connection
	ECU internal failure	Contact assistance, or replace ECU unit
309	ECU pin n.18 (OUT 09): external load is short circuit	Check harness and connection
	ECU internal failure	Contact assistance, or replace ECU unit
310	ECU pin n.21(OUT 10) is short to power +VB	Check harness and connection
	ECU internal failure	Contact assistance, or replace ECU unit
311	ECU pin n.21 (OUT 10) internal failure	Contact assistance, or replace ECU unit
	ECU internal failure	Contact assistance, or replace ECU unit
312	ECU watchdog failure ( internal short circuit )	replace ECU unit
	ECU internal failure	Contact assistance, or replace ECU unit
313	ECU pin n.21 (OUT 10): external load is open circuit	Check harness and connection
	ECU internal failure	Contact assistance, or replace ECU unit
314	ECU pin n.21 (OUT 10): external load is short circuit	Check harness and connection
	ECU internal failure	Contact assistance, or replace ECU unit
315	ECU pin n.22(OUT TM RELAY) is short to power +VB	Check harness and connection
	ECU internal failure	Contact assistance, or replace ECU unit
316	ECU pin n.22 (OUT TM RELAY) internal failure	Contact assistance, or replace ECU unit
	ECU internal failure	Contact assistance, or replace ECU unit
317	ECU watchdog failure ( internal short circuit )	replace ECU unit
	ECU internal failure	Contact assistance, or replace ECU unit
318	ECU pin n.22 (OUT TM RELAY): external load is open circuit	Check harness and connection
	ECU internal failure	Contact assistance, or replace ECU unit
319	ECU pin n.22 (OUT TM RELAY): external load is short circuit	Check harness and connection
	ECU internal failure	Contact assistance, or replace ECU unit

## Operating Instructions

Code	Possible failure reason	Suggested operation
320	ECU pin n.25(OUT BRAKE 1) is short to power +VB	Check harness and connection
	ECU internal failure	Contact assistance, or replace ECU unit
321	ECU pin n.25 (OUT BRAKE 1) internal failure	Contact assistance, or replace ECU unit
	ECU internal failure	Contact assistance, or replace ECU unit
322	ECU watchdog failure ( internal short circuit )	replace ECU unit
	ECU internal failure	Contact assistance, or replace ECU unit
323	ECU pin n.25 (OUT BRAKE 1): external load is open circuit	Check harness and connection
	ECU internal failure	Contact assistance, or replace ECU unit
324	ECU pin n.25 (OUT BRAKE 1): external load is short circuit	Check harness and connection
	ECU internal failure	Contact assistance, or replace ECU unit
325	ECU pin n.26(OUT BRAKE 2) is short to power +VB	Check harness and connection
	ECU internal failure	Contact assistance, or replace ECU unit
326	ECU pin n.26 (OUT BRAKE 2) internal failure	Contact assistance, or replace ECU unit
	ECU internal failure	Contact assistance, or replace ECU unit
327	ECU watchdog failure ( internal short circuit )	replace ECU unit
	ECU internal failure	Contact assistance, or replace ECU unit
328	ECU pin n.26 (OUT BRAKE 2): external load is open circuit	Check harness and connection
	ECU internal failure	Contact assistance, or replace ECU unit
329	ECU pin n.26 (OUT BRAKE 2): external load is short circuit	Check harness and connection
	ECU internal failure	Contact assistance, or replace ECU unit

For more information, please consult the appropriate Dingli Service Dept.

## Operating Instructions



### Battery and Charger Instructions

#### Observe and Obey:

- Do not use an external charger or booster battery.
- Charge the battery in a well-ventilated area.
- Use proper AC input voltage for charging as indicated on the charger.
- Use only a Dingli authorized battery and charger.

#### To Charge Battery

- 1 Be sure the batteries are connected before charging.
- 2 Open the battery compartment. The compartment should remain open for the entire charging cycle.

#### Maintenance - free battery

- 3 Connect the battery charger to a grounded AC circuit.
- 4 The charger will indicate when the battery is fully charged.

#### Standard Battery

- 5 Remove the battery vent caps and check the battery acid level. If necessary, add only enough distilled water to cover the plates. Do not overfill prior to the charge cycle.

- 6 Replace the battery vent caps.
- 7 Connect the battery charger to a grounded AC circuit.
- 8 The charger will indicate when the battery is fully charged.
- 9 Check the battery acid level when the charging cycle is complete. Replenish with distilled water to the bottom of the fill tube. Do not overfill.

#### Dry Battery Filling and Charging Instructions

- 1 Remove the battery vent caps and permanently remove the plastic seal from the battery vent openings.
- 2 Fill each cell with battery acid (electrolyte) until the level is sufficient to cover the plates.

Do not fill to maximum level until the battery charge cycle is complete. Overfilling can cause the battery acid to overflow during charging. Neutralize battery acid spills with baking soda and water.

- 3 Install the battery vent caps.
- 4 Charge the battery.
- 5 Check the battery acid level when the charging cycle is complete. Replenish with distilled water to the bottom of the fill tube. Do not overfill.

## Transport and Lifting Instructions



### Observe and Obey:

- Common sense and planning must be applied to control the movement of the machine when lifting it with a crane or forklift.
- Only qualified aerial lift operators should move the machine on or off the truck.
- The transport vehicle must be parked on a level surface.
- The transport vehicle must be secured to prevent rolling while the machine is being loaded.
- Be sure the vehicle capacity, loading surfaces and chains or straps are sufficient to withstand the machine weight. See the serial label for the machine weight.
- The machine must be on a level surface or secured before releasing the brakes.
- Do not allow the rails to fall when the snap pins are removed. Maintain a firm grasp on the rails when the rails are lowered.
- Do not drive the machine on a slope that exceeds the slope or side slope rating. See Driving on a Slope in the Operating Instructions section.
- If the slope of the transport vehicle bed exceeds the maximum slope rating, the machine must be loaded and unloaded using a winch as described.

### Brake Release Operation

- 1 Chock the wheels to prevent the machine from rolling.
- 2 Pull out the red Emergency Stop button to the on position at both the ground and platform controls.
- 3 Press and hold lift switch to “down” position in ground control, meanwhile turn on the key switch to the "Ground" position. The brake will be released after Alarm alerts.
- 4 If you want to close the brake release, just turn off the key switch in “ground” position.

Towing the Model is not recommended. If the machine must be towed, do not exceed 4.0 km/h.

### After the machine is loaded:

- 1 Push in both ground and platform red Emergency Stop buttons to the off position.
- 2 Turn the key switch to the off position.
- 3 Chock the wheels to prevent the machine from rolling.

---

## **Transport and Lifting Instructions**

### **Securing to Truck or Trailer for Transit**

Always chock the machine wheels in preparation for transport.

Retract and secure the extension deck(s).

Turn the key switch to the off position and remove the key before transporting.

Inspect the entire machine for loose or unsecured items.

Use the tie-down points on the chassis for anchoring down to the transport surface.

Use a minimum of four chains or straps.

Use chains or straps of ample load capacity.

If the railings have been folded down, secure them with straps before transporting.

### **Lifting the Machine with a Forklift**

Be sure the extension deck, controls and component trays are secure. Remove all loose items on the machine.

Fully lower the platform. The platform must remain lowered during all loading and transport procedures.

Use the forklift pockets located on both sides of the ladder.

Position the forklift forks in position with the forklift pockets.

Drive forward to the full extent of the forks.

Raise the machine 15 cm and then tilt the forks back slightly to keep the machine secure.

Be sure the machine is level when lowering the forks.

## Maintenance



### Observe and Obey:

- ✓ Only routine maintenance items specified in this manual shall be performed by the operator.
- ✓ Scheduled maintenance inspections shall be completed by qualified service technicians, according to the manufacturer's specifications and the requirements specified in this manual.

### Maintenance Symbols Legend

#### NOTICE

The following symbols have been used in this manual to help communicate the intent of the instructions. When one or more of the symbols appear at the beginning of a maintenance procedure, it conveys the meaning below.



Indicates that tools will be required to perform this procedure.



Indicates that new parts will be required to perform this procedure.



Indicates that dealer service will be required to perform this procedure.

### Pre-delivery Preparation Report

The pre-delivery preparation report contains checklists for each type of scheduled inspection.

Make copies of the Pre-delivery Preparation report to use for each inspection. Store completed forms as required.

### Maintenance Schedule

There are five types of maintenance inspections that must be performed according to a schedule— daily, quarterly, semi-annually, annually, and two year. The Scheduled Maintenance Procedures Section and the Maintenance Inspection Report have been divided into five subsections—A, B, C, D, and E. Use the following chart to determine which group(s) of procedures are required to perform a scheduled inspection.

Inspection	Checklist
Daily or every 8 hours	A
Quarterly or every 250 hours	A+B
Semi-annually or every 500 hours	A+B+C
Annually or every 1000 hours	A+B+C+D
Two year or every 2000 hours	A+B+C+D+E

### Maintenance Inspection Report

The maintenance inspection report contains checklists for each type of scheduled inspection.

Make copies of the Maintenance Inspection Report to use for each inspection. Maintain completed forms for a minimum of 4 years or in compliance with your employer, jobsite and governmental regulations and requirements.



## Maintenance

### Pre-delivery Preparation Report

#### Fundamentals

It is the responsibility of the dealer to perform the Pre-delivery Preparation.

The Pre-delivery Preparation is performed prior to each delivery. The inspection is designed to discover if anything is apparently wrong with a machine before it is put into service.

A damaged or modified machine must never be used. If damage or any variation from factory delivered condition is discovered, the machine must be tagged and removed from service.

Repairs to the machine may only be made by a qualified service technician, according to the manufacturer's specifications.

Scheduled maintenance inspections shall be performed by qualified service technicians, according to the manufacturer's specifications and the requirements listed in this manual.

#### Instructions

Use the operator's manual on your machine.

The Pre-delivery Preparation consists of completing the Pre-operation Inspection, the Maintenance items and the Function Tests.

Use this form to record the results. Place a check in the appropriate box after each part is completed. Follow the instructions in the operator's manual.

If any inspection receives an N, remove the machine from service, repair and re-inspect it. After repair, place a check in the R box.

#### Legend

Y = yes, completed

N = no, unable to complete

R = repaired

#### Comments

Pre-Delivery Preparation	Y	N	R
Pre-operation inspection completed			
Maintenance items completed			
Function tests completed			

Model

Serial number

Date

Machine owner

Inspected by (print)

Inspector signature

Inspector title

Inspector company

# Maintenance

## Maintenance Inspection Report

<b>Model</b>
<b>Serial number</b>
<b>Date</b>
<b>Hour meter</b>
<b>Machine owner</b>
<b>Inspected by (print)</b>
<b>Inspector signature</b>
<b>Inspector title</b>
<b>Inspector company</b>
<b>Instructions</b>
<ul style="list-style-type: none"> <li>• Make copies of this report to use for each inspection.</li> <li>• Select the appropriate checklist(s) for the type of inspection to be performed.</li> </ul>
<input type="checkbox"/> Daily or 8 hours Inspection: <span style="float: right;">A</span>
<input type="checkbox"/> Quarterly or 250 hours Inspection: <span style="float: right;">A+B</span>
<input type="checkbox"/> Semi-annually or 500 hours Inspection: <span style="float: right;">A+B+C</span>
<input type="checkbox"/> Annually or 1000 hours Inspection: <span style="float: right;">A+B+C+D</span>
<input type="checkbox"/> Two year or 2000 hours Inspection: <span style="float: right;">A+B+C+D+E</span>
<ul style="list-style-type: none"> <li>• Place a check in the appropriate box after each inspection procedure is completed.</li> <li>• Use the step-by-step procedures in this section to learn how to perform these inspections.</li> <li>• If any inspection receives an “N”, tag and remove the machine from service, repair and re-inspect it. After repair, place a check in the “R” box.</li> </ul>
<b>Legend</b>
Y = yes, acceptable
N = no, remove from service
R = repaired

<b>Checklist A</b>	Y	N	R
A-1 Inspect the manuals and decals			
A-2 Pre-operation inspection			
A-3 Check the Batteries			
A-4 Check the Hydraulic Oil Level			
A-5 Function tests			
<b>Perform after 40 hours:</b>			
A-6 30 day service			
<b>Checklist B</b>	Y	N	R
B-1 Batteries			
B-2 Electrical wiring			
B-3 Tires and wheels			
B-4 Emergency stop			
B-5 Key switch			
B-6 Horn (if equipped)			
B-7 Drive brakes			
B-8 Drive speed - stowed			
B-9 Drive speed - raised			
B-10 Drive speed - slow			
B-11 Hydraulic oil analysis			
B-12 Tank venting system			
B-13 Slider components			
<b>Checklist C</b>	Y	N	R
C-1 Platform overload (if equipped)			
C-2 Breather cap - models with optional oil			
<b>Checklist D</b>	Y	N	R
D-1 Scissor arm wear pads			
<b>Checklist E</b>	Y	N	R
E-1 Hydraulic oil			

## Checklist A Procedures

### A-1

#### Inspect the Manuals and Decals

Maintaining the operator's manual in good condition is essential to safe machine operation. Manuals are included with each machine and should be stored in the container provided in the platform. An illegible or missing manual will not provide safety and operational information necessary for a safe operating condition.

In addition, maintaining all of the safety and instructional decals in good condition is mandatory for safe machine operation. Decals alert operators and personnel to the many possible hazards associated with using this machine. They also provide users with operation and maintenance information. An illegible decal will fail to alert personnel of a procedure or hazard and could result in unsafe operating conditions.

- 1 Check to make sure that the operator's manual is present and complete in the storage container on the platform.
- 2 Examine the pages of manual to be sure that they are legible and in good condition.

☉ Result: The operator's manual is appropriate for the machine and the manual are legible and in good condition.

☒ Result: The operator's manual is not appropriate for the machine or the manual is not in good condition or is illegible. Remove the machine from service until the manual is replaced.

- 3 Open the operator's manual to the decals inspection section. Carefully and thoroughly inspect all decals on the machine for legibility and damage.

☉ Result: The machine is equipped with all required decals, and all decals are legible and in good condition.

☒ Result: The machine is not equipped with all required decals, or one or more decals are illegible or in poor condition. Remove the machine from service until the decals are replaced.

- 4 Always return the manual to the storage container after use.

Note: Contact your authorized DINGLI distributor or DINGLI machinery if replacement manuals or decals are needed.

## Maintenance

### A-2

#### Perform Pre-operation Inspection

Completing a Pre-operation Inspection is essential to safe machine operation. The Pre-operation Inspection is a visual inspection performed by the operator prior to each work shift. The inspection is designed to discover if anything is apparently wrong with a machine before the operator performs the function tests. The Pre-operation Inspection also serves to determine if routine maintenance procedures are required.

Complete information to perform this procedure is available in the appropriate operator's manual. Refer to the operator's manual on your machine.

### A-3

#### Check the Batteries



Proper battery condition is essential to good machine performance and operational safety. Improper fluid levels or damaged cables and connections can result in component damage and hazardous conditions.

**⚠ WARNING** Electrocution hazard. Contact with hot or live circuits may result in death or serious injury. Remove all rings, watches and other jewelry.

**⚠ WARNING** Bodily injury hazard. Batteries contain acid. Avoid spilling or contacting battery acid. Neutralize battery acid spills with baking soda and water.

- 1 Put on protective clothing and eye wear.
- 2 Be sure that the battery cable connections are tight and free of corrosion.
- 3 Be sure that the battery hold-down bars are secure.
- 4 Remove the battery vent caps.
- 5 Check the battery acid level. If needed, replenish with distilled water to the bottom of the battery fill tube. Do not overfill.
- 6 Install the vent caps.

**A-4****Check the Hydraulic Oil Level**

Maintaining the hydraulic oil at the proper level is essential to machine operation. Improper hydraulic oil levels can damage hydraulic components. Daily checks allow the inspector to identify changes in oil level that might indicate the presence of hydraulic system problems.

**NOTICE**

Perform this procedure with the platform in the stowed position and the motor off.

- 1 Remove the hydraulic oil dipstick (fill cap), wipe it clean and reinstall it.
- 2 Take the hydraulic oil dipstick out again, and check the oil level.
- 3 If the hydraulic oil level is too low and add new hydraulic oil to the prescribed level.

**NOTICE**

**Original Hydraulic oil specifications: L-HV46**

Customers shall choose the appropriate hydraulic oil according to the ambient temperature used.

Example: L-HV32 or L-HV68

**A-5****Perform Function Tests**

Completing the function tests is essential to safe machine operation. Function tests are designed to discover any malfunctions before the machine is put into service. A malfunctioning machine must never be used. If malfunctions are discovered, the machine must be tagged and removed from service.

Complete information to perform this procedure is available in the appropriate operator's manual. Refer to the operator's manual on your machine.

## Maintenance

### A-6

#### Perform 30 Day Service



The 30 day maintenance procedure is a one time procedure to be performed after the first 30 days or 40 hours of usage. After this interval, refer to the maintenance tables for continued scheduled maintenance.

Perform the following maintenance procedures:

B-3 Inspect the Tires, Wheels and lock Nut Torque

**Checklist B Procedures****B-1****Inspect the Batteries**

DINGLI requires that this procedure be performed every 250 hours or quarterly, whichever comes first.

Proper battery condition is essential to good machine performance and operational safety. Improper fluid levels or damaged cables and connections can result in component damage and hazardous conditions.

**⚠ WARNING** Electrocuting / burn hazard. Contact with electrically charged circuits could result in death or serious injury. Remove all rings, watches and other jewelry.

**⚠ WARNING** Bodily injury hazard. Batteries contain acid. Avoid spilling or contacting battery acid. Neutralize battery acid spills with baking soda and water.

- 1 Put on protective clothing and eye wear.
- 2 Side out tray and away from the chassis.
- 3 Be sure that the battery cable connections are free of corrosion.

Note: Adding terminal protectors and a corrosion preventative sealant will help eliminate corrosion on the battery terminals and cables.

- 4 Be sure that the battery retainers and cable connections are tight.
- 5 Fully charge the batteries. Allow the batteries to rest 24 hours before performing this procedure to allow the battery cells to equalize.

**Models without maintenance-free or sealed batteries:**

- 6 Remove the battery vent caps and check the specific gravity of each battery cell with a hydrometer. Note the results.
- 7 Check the ambient air temperature and adjust the specific gravity reading for each cell as follows:
  - Add 0.004 to the reading of each cell for every 5.5°C above 26.7°C.
  - Subtract 0.004 from the reading of each cell for every 5.5°C below 26.7°C.
- ☉ Result: All battery cells display an adjusted specific gravity of 1.277 or higher. The battery is fully charged. Proceed to step 11.
- ☒ Result: One or more battery cells display a specific gravity of 1.217 or below. Proceed to step 8.
- 8 Perform an equalizing charge OR fully charge the batteries and allow the batteries to rest at least 6 hours.
- 9 Remove the battery vent caps and check the specific gravity of each battery cell with a hydrometer. Note the results.
- 10 Check the ambient air temperature and adjust the specific gravity reading for each cell as follows:
  - Add 0.004 to the reading of each cell for every 5.5°C above 26.7°C.
  - Subtract 0.004 from the reading of each cell for every 5.5°C below 26.7°C.
- ☉ Result: All battery cells display a specific gravity of 1.277 or greater. The battery is fully charged. Proceed to step 11.
- ☒ Result: The difference in specific gravity

## Maintenance

readings between cells is greater than 0.1 OR the specific gravity of one or more cells is less than 1.177. Replace the battery.

- 11 Check the battery acid level. If needed, replenish with distilled water to 3 mm below the bottom of the battery fill tube. Do not overfill.
- 12 Install the vent caps and neutralize any electrolyte that may have spilled.

Note: If you have any further questions regarding the battery charger operation, please contact the DINGLI Service Department.

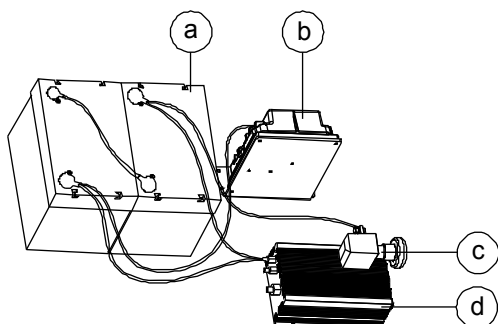

- a batteries
- b 150A fuse
- c power switch
- d battery charger

### All models:

- 13 Check each battery pack and verify that the batteries are wired correctly.
  - 14 Inspect the battery charger plug and pigtail for damage or excessive insulation wear. Replace as required.
  - 15 Connect the battery charger to a properly grounded 110 - 230V / 50 - 60 Hz single phase AC power supply.
- ☉ Result: The charger should operate and begin charging the batteries.
  - ☒ Result: If, simultaneously, the charger alarm sounds and the LEDs blink, correct the charger connections at the fuse and battery. The charger will then operate correctly and begin charging the batteries.

Note: For best results, use an extension of adequate size with a length no longer than 15m.



**B-2****Inspect the Electrical Wiring**

DINGLI requires that this procedure be performed every 250 hours or quarterly, whichever comes first.

Maintaining electrical wiring in good condition is essential to safe operation and good machine performance. Failure to find and replace burnt, chafed, corroded or pinched wires could result in unsafe operating conditions and may cause component damage.

**⚠ WARNING** Electrocutation / burn hazard. Contact with electrically charged circuits could result in death or serious injury. Remove all rings, watches and other jewelry.

- 1 Inspect the underside of the chassis for damaged or missing ground strap(s).
- 2 Inspect the following areas for burnt, chafed, corroded and loose wires:
  - Ground control panel
  - Hydraulic power unit module tray
  - Platform controls
- 3 Turn the key switch to ground control and pull out the red Emergency Stop button to the on position at both the ground and platform controls.
- 4 Raise the platform until the distance of the two sets of scissor at least 0.4m.
- 5 Lift the safety arm, move it to the center of the scissor arm and rotate down to a vertical position.
- 6 Lower the platform until the safety arm rests securely on the link. Keep clear of the safety arm when lowering the platform.

**⚠ WARNING** Crushing hazard. Keep hands clear of the safety arm when lowering the platform.

- 7 Inspect the center chassis area and scissor arms for burnt, chafed and pinched cables.
- 8 Inspect the following areas for burnt, chafed, corroded, pinched and loose wires:
  - Scissor arms
  - ECU to platform controls
  - Power to platform wiring
- 9 Inspect for a liberal coating of dielectric grease in the following locations:
  - Between the ECU and platform controls
  - All wire harness connectors Level sensor
- 10 Raise the platform and return the safety arm to the stowed position.
- 11 Lower the platform to the stowed position and turn the machine off.

## Maintenance

### B-3

#### Inspect the Tires and Wheels (including lock nut torque)



DINGLI requires that this procedure be performed every 250 hours or quarterly, whichever comes first.

Maintaining the tires and wheels in good condition is essential to safe operation and good performance. Tire and/or wheel failure could result in a machine tip-over. Component damage may also result if problems are not discovered and repaired in a timely fashion.

- 1 Check the tire surface and sidewalls for cuts, cracks, punctures and unusual wear.
- 2 Check each wheel for damage, bends and cracks.
- 3 Check each lock nut for proper torque.

Castle nut torque, dry	89Nm
Castle nut torque, lubricated	65Nm

### B-4

#### Test the Emergency Stop

DINGLI requires that this procedure be performed every 250 hours or quarterly, whichever comes first.

A properly functioning Emergency Stop is essential for safe machine operation. An improperly operating red Emergency Stop button will fail to shut off power and stop all machine functions, resulting in a hazardous situation.

As a safety feature, selecting and operating the ground controls will override the platform controls, except the platform red Emergency Stop button.

- 1 Turn the key switch to ground control and pull out the red Emergency Stop button to the on position at both the ground and platform controls.
  - 2 Push in the red Emergency Stop button at the ground controls to the off position.
- ⊙ Result: No machine functions should operate.
- 3 Turn the key switch to platform control and pull out the red Emergency Stop button to the on position at both the ground and platform controls.
  - 4 Push in the red Emergency Stop button at the platform controls to the off position.
- ⊙ Result: No machine functions should operate.

Note: The red Emergency Stop button at the ground controls will stop all machine operation, even if the key switch is switched to platform control.

**B-5****Test the Key Switch**

DINGLI requires that this procedure be performed every 250 hours or quarterly, whichever comes first.

Proper key switch action and response is essential to safe machine operation. The machine can be operated from the ground or platform controls and the activation of one or the other is accomplished with the key switch. Failure of the key switch to activate the appropriate control panel could cause a hazardous operating situation.

Perform this procedure from the ground using the platform controls. Do not stand in the platform.

- 1 Pull out the red Emergency Stop button to the on position at both the ground and platform controls.
- 2 Turn the key switch to platform control.
- 3 Check the platform up/down function from the ground controls.
- ⊙ Result: The machine functions should not operate.
- 4 Turn the key switch to ground control.
- 5 Check the machine functions from the platform controls.
- ⊙ Result: The machine functions should not operate.
- 6 Turn the key switch to the off position.
- ⊙ Result: No function should operate.

**B-6****Test the Automotive-style Horn (if equipped)**

DINGLI requires that this procedure be performed every 250 hours or quarterly, whichever comes first.

The horn is activated at the platform controls and sounds at the ground as a warning to ground personnel. An improperly functioning horn will prevent the operator from alerting ground personnel of hazards or unsafe conditions.

- 1 Turn the key switch to platform control and pull out the red Emergency Stop button to the on position at both the ground and platform controls.
- 2 Push down the horn button at the platform controls.
- ⊙ Result: The horn should sound.

## Maintenance

### B-7

#### Test the Drive Brakes



DINGLI requires that this procedure be performed every 250 hours or quarterly, whichever comes first.

Proper brake action is essential to safe machine operation. The drive brake function should operate smoothly, free of hesitation, jerking and unusual noise.

Hydraulically-released individual wheel brakes can appear to operate normally when not fully operational.

Perform this procedure with the machine on a firm level surface that is free of obstructions, with the platform extension deck fully retracted and the platform in the stowed position.

- 1 Mark a test line on the ground for reference.
- 2 Turn the key switch to platform control and pull out the red Emergency Stop button to the on position at both the ground and platform controls.
- 3 Lower the platform to the stowed position.
- 4 Press the drive function select button.
- 5 Choose a point on the machine; i.e., contact patch of a tire, as a visual reference for use when crossing the test line.
- 6 Bring the machine to top drive speed before reaching the test line. Release the function enable switch or the joystick when your reference point on the machine crosses the test line.
- 7 Measure the distance between the test line and your machine reference point.

⊙ Result: The machine stops within the specified braking distance. No action required.

⊗ Result: The machine does not stop within the specified braking distance.

Note: The brakes must be able to hold the machine on any slope it is able to climb.

- 8 Replace the brakes and repeat this procedure beginning with step 1.

---

#### Braking distance, maximum

---

High range on paved surface    61 cm ± 30 cm

---

**B-8****Test the Drive Speed - Stowed Position**

DINGLI requires that this procedure be performed every 250 hours or quarterly, whichever comes first.

Proper drive functions are essential to safe machine operation. The drive function should respond quickly and smoothly to operator control. Drive performance should also be free of hesitation, jerking and unusual noise over the entire proportionally controlled speed range.

Perform this procedure with the machine on a firm, level surface that is free of obstructions.

- 1 Create start and finish lines by marking two lines on the ground 12.2 m apart.
- 2 Turn the key switch to platform control and pull out the red Emergency Stop button to the on position at both the ground and platform controls.
- 3 Lower the platform to the stowed position.
- 4 Press the drive function select button.
- 5 Choose a point on the machine; i.e., contact patch of a tire, as a visual reference for use when crossing the start and finish lines.
- 6 Bring the machine to top drive speed before reaching the start line. Begin timing when your reference point on the machine crosses the start line.
- 7 Continue at full speed and note the time when your reference point on the machine passes over the finish line. The time is less than 11 sec.

**B-9****Test the Drive Speed-Raised Position**

DINGLI requires that this procedure be performed every 250 hours or quarterly, whichever comes first.

Proper drive functions are essential to safe machine operation. The drive function should respond quickly and smoothly to operator control. Drive performance should also be free of hesitation, jerking and unusual noise over the entire proportionally controlled speed range.

Perform this procedure with the machine on a firm, level surface that is free of obstructions.

- 1 Create start and finish lines by marking two lines on the ground 12.2 m apart.
- 2 Turn the key switch to platform control and pull out the red Emergency Stop button to the on position at both the ground and platform controls.
- 3 Press the lift function select button.
- 4 Press and hold the function enable switch on the joystick.
- 5 Raise the platform approximately 1.2 m from the ground.
- 6 Press the drive function select button.
- 7 Choose a point on the machine; i.e., contact patch of a tire, as a visual reference for use when crossing the start and finish lines.
- 8 Bring the machine to top drive speed before reaching the start line. Begin timing when your reference point on the machine crosses the start line.
- 9 Continue at full speed and note the time when your reference point on the machine passes over the finish line. The time is less than 88sec.

## Maintenance

### B-10

#### Test the Slow Drive Speed



DINGLI requires that this procedure be performed every 250 hours or quarterly, whichever comes first.

Proper drive functions are essential to safe machine operation. The drive function should respond quickly and smoothly to operator control. Drive performance should also be free of hesitation, jerking and unusual noise over the entire proportionally controlled speed range.

Perform this procedure with the machine on a firm, level surface that is free of obstructions.

- 1 Create start and finish lines by marking two lines on the ground 12.2 m apart.
- 2 Turn the key switch to platform control and pull out the red Emergency Stop button to the on position at both the ground and platform controls.
- 3 Lower the platform to the stowed position.
- 4 Press the slow speed select button.
- 5 Choose a point on the machine; i.e., contact patch of a tire, as a visual reference for use when crossing the start and finish lines.
- 6 Bring the machine to top drive speed before reaching the start line. Begin timing when your reference point on the machine crosses the start line.
- 7 Continue at full speed and note the time when your reference point on the machine passes over the finish line. The time is less than 22 sec.

### B-11

#### Perform Hydraulic Oil Analysis



DINGLI requires that this procedure be performed every 250 hours or quarterly, whichever comes first.

Replacement or testing of the hydraulic oil is essential for good machine performance and service life. Dirty oil may cause the machine to perform poorly and continued use may cause component damage. Extremely dirty conditions may require oil changes to be performed more often.

Before replacing the hydraulic oil, the oil may be tested by an oil distributor for specific levels of contamination to verify that changing the oil is necessary.

If the hydraulic oil is not replaced at the two year inspection, test the oil quarterly. Replace the oil when it fails the test. See E-1, Test or Replace the Hydraulic Oil.

**B-12****Inspect the Hydraulic Tank Cap Venting System**

DINGLI requires that this procedure be performed quarterly or every 250 hours, whichever comes first. Perform this procedure more often if dusty conditions exist.

A free-breathing hydraulic tank cap is essential for good machine performance and service life. A dirty or clogged cap may cause the machine to perform poorly. Extremely dirty conditions may require that the cap be inspected more often.

- 1 Remove the breather cap from the hydraulic tank.
- 2 Check for proper venting.
  - ☉ Result: Air passes through the breather cap.
  - ☐ Result: If air does not pass through the cap, clean or replace the cap. Proceed to step 3.

Note: When checking for positive tank cap venting, air should pass freely through the cap.

- 3 Using a mild solvent, carefully wash the cap venting system. Dry using low pressure compressed air. Repeat step 2.
- 4 Install the breather cap onto the hydraulic tank.

**B-13****Check the Module Tray slider Components**

DINGLI requires that this procedure be performed every 250 hours or quarterly, whichever comes first.

Maintaining the module tray slider components in good condition is essential to good performance and service life. Failure to detect worn out slider components may result in module trays opening unexpectedly, creating an unsafe operating condition.

- 1 Inspect the module tray slider and related components for wear. Tighten any loose fasteners.
- 2 Lubricate each module tray slider. Using light oil, apply a few drops to each of the slider and to the ball of the roll mechanism.

# Maintenance

## Checklist C Procedures

### C-1

#### Test the Platform Overload System (if equipped)



DINGLI requires that this procedure be performed every 500 hours or six months, whichever comes first or when the machine fails to lift the maximum rated load.

Testing the platform overload system regularly is essential to safe machine operation. Continued use of an improperly operating platform overload system could result in the system not sensing an overloaded platform condition. Machine stability could be compromised resulting in the machine tipping over.

- 1 Turn the main power switch to “on” position. Turn the key switch to ground control and pull out the red Emergency Stop button to the on position at both the ground and platform controls.



- 2 Press the menu button at the lower right of the page, The display content is as follows:

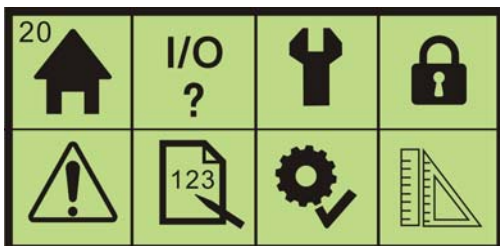

- 3 Press the password button at the top right of the page The display content is as follows:

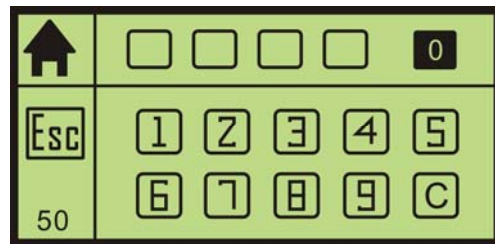

- 4 Enter the password. Press the [ESC] button and return to the display content of step 2.
- 5 Press the [123] button, the display content is as follows:

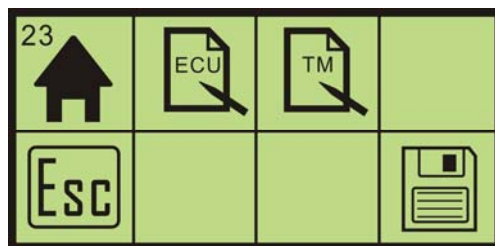

- 6 Press the [ECU] button, the display content is as follows:

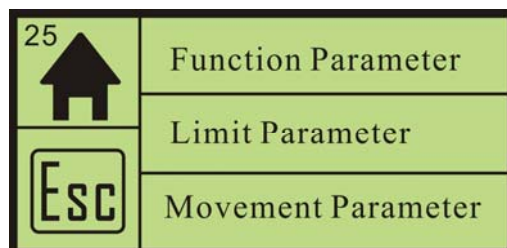

- 7 Press the [limit parameter] button, press the left or right button to choose [height Max Position] and set the page, press[+] button to set the parameter to 120.Press the enter button, The display content is as follows:

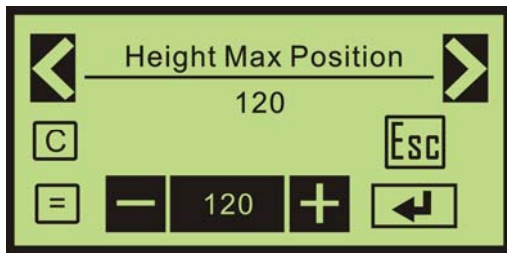

**Maintenance**

- 8 Press the [ESC] button then return to the display page of step 5.
  - 9 Fully raise the platform. Hold the toggle switch for a moment.
- ⊙ Result -The alarm should sound. The system is functioning correctly.

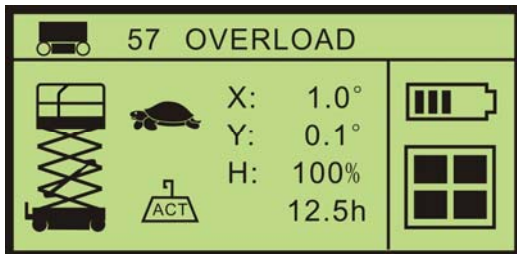

- ⊘ Result: The alarm not sounds. The system is not functioning correctly. Troubleshoot the limit switch, limit switch wire harness or limit switch mount bracket OR the platform overload system needs to be calibrated.
- 10 Lower the platform to the stowed position and turn the machine off.

**C-2****Replace the Hydraulic Tank Breather Cap**

DINGLI requires that this procedure be performed every 500 hours or semi-annually, whichever comes first.

The hydraulic tank is a vented-type tank. The breather cap has an internal air filter that can become clogged or, over time, can deteriorate. If the breather cap is faulty or improperly installed, impurities can enter the hydraulic system which may cause component damage. Extremely dirty conditions may require that the cap be inspected more often.

- 1 Remove and discard the hydraulic tank breather cap.
- 2 Install a new cap onto the tank.

## Maintenance

### Checklist D Procedures

#### D-1

#### Check the Scissor Arm Wear Pads



DINGLI requires that this procedure be performed every 1000 hours or annually, whichever comes first.

Maintaining the condition of the scissor arm wear pads is essential to safe machine operation. Continued use of worn out wear pads may result in component damage and unsafe operating conditions.

Perform this procedure with the platform in the stowed position.

- 1 Measure the distance between the number one arm cross tube and the chassis deck at the left side of the steer end of the machine.

☉ Result: The measurement is 22 mm or more. Proceed to step 2.

☒ Result: The measurement is less than 22 mm. Replace both wear pads.

- 2 Measure the distance between the number one arm cross tube and the chassis deck at the right side of the steer end of the machine.

☉ Result: The measurement is 22 mm or more. Proceed to step 3.

☒ Result: The measurement is less than 22mm. Replace both wear pads.

- 3 Apply a thin layer of dry film lubricant to the area of the chassis where the scissor arm wear pads make contact.

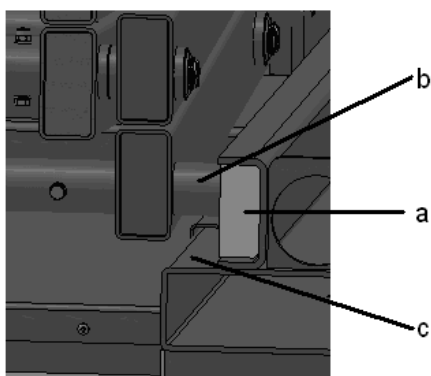

- a wear pad
- b arm cross tube
- c chassis deck

## Checklist E Procedure

### E-1

#### Test or Replace the Hydraulic Oil



DINGLI requires that this procedure be performed every 2000 hours or every two years, whichever comes first.

Replacement or testing of the hydraulic oil is essential for good machine performance and service life. Dirty oil may cause the machine to perform poorly and continued use may cause component damage. Extremely dirty conditions may require oil changes to be performed more often.

Before replacing the hydraulic oil, the oil may be tested by an oil distributor for specific levels of contamination to verify that changing the oil is necessary.

If the hydraulic oil is not replaced at the two year inspection, test the oil quarterly. Replace the oil when it fails the test.

Note: Perform this procedure with the platform in the stowed position.

- 1 Slide out the tray.
- 2 Disconnect the battery pack from the machine.

**⚠ WARNING** Electrocutation / burn hazard. Contact with electrically charged circuits could result in death or serious injury. Remove all rings, watches and other jewelry.

- 3 Tag and disconnect the hydraulic pump outlet line and remove the line from the pump. Cap the fitting on the pump.
- 4 Tag and disconnect the electric wires from the motor.
- 5 Loose the bolt and remove the hydraulic power pack form the tray.

- 6 Remove the oil drain plug at bottom.
- 7 Drain all of the oil into a suitable container.
- 8 Loose and remove the bolts and separate the tank from the pump body.

**⚠ WARNING** Bodily injury hazard. Spraying hydraulic oil can penetrate and burn skin. Loosen hydraulic connections very slowly to allow the oil pressure to dissipate gradually. Do not allow oil to squirt or spray.

- 9 Clean up any oil that may have spilled. Properly discard the used oil.
- 10 Clean the inside of the hydraulic tank using a mild solvent. Allow the tank to dry completely.
- 11 Install a new filter onto the tank.
- 12 Install the hydraulic tank and install and tighten the hydraulic tank retaining fasteners. Torque to specification.

#### Torque specifications

Hydraulic tank retaining fasteners, dry	4Nm
Hydraulic tank drain plug, lubricated	2.9Nm

- 13 Install the hydraulic power pack into the tray.
- 14 Install the fitting and hydraulic hoses onto the hydraulic power pack and torque.
- 15 Install the electric wires to pump motor.
- 16 Fill the tank with hydraulic oil until the fluid is full in the hydraulic tank. Do not overfill.
- 17 Activate the pump to fill the hydraulic system with oil and bleed the system of air.

## Maintenance

**⚠ WARNING** Component damage hazard.

The pump can be damaged if operated without oil. Be careful not to empty the hydraulic tank while in the process of filling the hydraulic system. Do not allow the pump to cavitate.

# Schematic

## Hydraulic Schematic

