

SELF-PROPELLED MAST LIFTS OPERATOR'S MANUAL

with Maintenance Information

(For MV080J/ MV095J)

(Series 3)



WARNING

THE MANUFACTURER SHALL NOT BE HELD LIABLE IN CASE OF FAULTS OR ACCIDENTS DUE TO NEGLIGENCE, INCAPACITY, INSTALLATION BY UNQUALIFIED TECHNICIANS AND IMPROPER USE OF THE MACHINE

DO NOT OPERATE THIS MACHINE UNTIL YOU READ AND UNDERSTAND ALL THE DANGERS, WARNINGS AND CAUTIONS IN THIS MANUAL

Part Number: SM0513111A

Important

Read, understand and obey these safety rules and operating instructions before operating this machine.

Only trained and authorized personnel shall be permitted to operate this machine. This manual should be considered a permanent part of your machine and should remain with the machine at all times. If you have any questions, please call DINGLI Machinery.

Contents

	Page
Safety Rules	1
Legend	8
Decals	9
Specifications	13
Control panel	15
Pre-operation Inspection	18
Workplace Inspection	20
Function Tests	21
Operating Instructions	26
Transport and Lifting Instructions	31
Maintenance	34
Schematic	56
Inspection and Repair Log	58

Owners, Users and operators:

Dingli appreciates your choice of our machine for your application. User's safety is our priority, so we hope you can:

- 1 Comply with employer, job site and governmental rules.
- 2 Read, understand and follow the instructions in this and other manuals supplied with this machine.
- 3 Use good safe work practices in a commonsense way.
- 4 Only have trained / certified operators, directed by informed and knowledgeable supervision, running the machine.

If there is anything in this manual that is not clear or which you believe should be added, please contact us.

Contact us:

Zhejiang Dingli Machinery Co., Ltd.

1255 Baiyun South Road. Leidian Town.

Deqing Zhejiang

China

Tel: +86-572-8681688

Fax: +86-572-8681690

Web: www.cndingli.com

E-mail: market@cndingli.com

Safety Rules



Danger

Failure to obey the instructions and safety rules in this manual will result in death or serious injury.

Do Not Operate Unless:

- You learn and practice the principles of safe machine operation contained in this operator's manual.
 - 1 **Avoid hazardous situations.**
 - Know and understand the safety rules before going on to the next section.**
 - 2 Always perform a pre-operation inspection.
 - 3 Always perform function tests prior to use.
 - 4 Inspect the workplace.
 - 5 Only use the machine as it was intended.
- You read, understand and obey the manufacturer's instructions and safety rules— safety and operator's manuals and machine decals.
- You read, understand and obey employer's safety rules and worksite regulations.
- You read, understand and obey all applicable governmental regulations.
- You are properly trained to safely operate the machine.

Decal Legend

DINGLI product decals use symbols, color coding and signal words to identify the following:



Safety alert symbol — used to alert personnel to potential personal injury hazards. Obey all safety messages that follow this symbol to avoid possible injury or death.



DANGER Red — used to indicate the presence of an imminently hazardous situation which, if not avoided, will result in death or serious injury.



WARNING Orange — used to indicate the presence of a potentially hazardous situation which, if not avoided, could result in death or serious injury.



CAUTION Yellow with safety alert symbol — used to indicate the presence of a potentially hazardous situation which, if not avoided, may cause minor or moderate injury.



NOTICE Blue without safety alert symbol — used to indicate the presence of a potentially hazardous situation which, if not avoided, may result in property damage.

Safety Rules

The relevant conditions of using the equipment

The surface of work ground should be flat and hard with no obstacles in air and the safety distance between the equipment and high-tension line is adequate.

The environment temperature should be within $-20^{\circ}\text{C}\sim 40^{\circ}\text{C}$; Height above sea level $\leq 1000\text{m}$.

The environment humidity $\leq 90\%$.

Electrical power: AC $110\sim 230\text{V}\pm 10\%$, $50\sim 60\text{Hz}$.

Work cycle

The life of designed work cycle is no more than 40000 times

Intended Use

This machine is intended to be used only to lift personnel, along with their tools and materials to an aerial work site.

Safety Sign Maintenance

Replace any missing or damaged safety signs. Keep operator safety in mind at all times. Use mild soap and water to clean safety signs. Do not use solvent-based cleaners because they may damage the safety sign material.

Operator

Only the trained and qualified are permitted to operate this machine. Always use safety belt and helmet when aerially working.

If you are subject to dizziness or seizures, or are bothered by heights, you must not operate this type of machinery.

An operator must not use drugs or alcohol that can change his/her alertness or coordination. An operator on prescription or

over-the-counter drugs needs medical advice on whether or not he/she can safely operate machines.

⚠ Electrocutation Hazard

This machine is not electrically insulated and will not provide protection from contact with or proximity to electrical current.



Maintain safe distances from electrical power lines and apparatus in accordance with applicable governmental regulations and the following chart.

Voltage Phase to Phase	Minimum Safe Approach Distance Meters
0 to 300V	Avoid Contact
300V to 50KV	3.05
50KV to 200KV	4.60
200KV to 350KV	6.10
350KV to 500KV	7.62
500KV to 750KV	10.67
750KV to 1000KV	13.72

Allow for platform movement, electrical line sway or sag and beware of strong or gusty winds.

Keep away from the machine if it contacts energized power lines. Personnel on the ground or in the platform must not touch or operate the machine until energized power lines are shut off.

Do not operate the machine during lightning or storms.

Safety Rules

Do not use the machine as a ground for welding.

Keep clear of live electric conductors.

▲ Tip-over Hazard

Occupants, equipment and materials must not exceed the maximum platform capacity

Maximum capacity – MV080J

Maximum capacity – MV095J

Maximum occupants (Indoor use) 2

Maximum occupants (Outdoor use) 1

Platform allowable maximum load 200 kg

Work Area Safety

Do not raise the platform unless the machine is on a firm, level surface.

Do not install any objects that would increase the wind loading on the MEWP.

Do not drive over 0.5km/h with the platform raised.



DO not depend on the tilt alarm as a level indicator. The tilt alarm sounds on the chassis and in the platform when the machine is on a slope.

If the tilt alarm sounds:

Lower the mast, and then lower the jib boom. Move the machine to a firm, level surface. Use extreme caution to lower the mast.

For outdoor use machine, do not raise the platform when wind speeds may exceed

12.5m/s. If wind speeds exceed 12.5m/s when the platform is raised, lower the platform and do not continue to operate the machine.

When raising the platform, follow ratings for allowable manual force and number of occupants below.

Do not operate the machine in strong or gusty winds. Do not increase the surface area of the platform or the load. Increasing the area exposed to the wind will decrease machine stability.



Do not use the platform controls to free a platform that is caught, snagged or otherwise prevented from normal motion by an adjacent structure. All personnel must be removed from the platform before attempting to free the platform using the ground controls.

Use extreme care and slow speeds while driving the machine in the stowed position across uneven terrain, debris, unstable or slippery surfaces and near holes and drop-offs.

Do not drive the machine on or near uneven terrain, unstable surfaces or other hazardous conditions with the boom raised or extended

Do not use the machine as a crane.

Do not push off or pull toward any object outside of the platform.



Safety Rules

Maximum allowable manual force

Model	Application	manual force	Maximum occupants
MV080J	Outdoor	200N	1
	Indoor	400N	2
MV095J	Outdoor	200N	1
	Indoor	400N	2

Do not alter or disable the limit switches.

Do not alter or disable machine components that in any way affect safety and stability.

Do not replace items critical to machine stability with items of different weight or specification.

Do not modify or alter an aerial work platform without prior written permission from the manufacturer. Mounting attachments for holding tools or other materials onto the platform, toe boards or guard rail system can increase the weight in the platform and the surface area of the platform or the load.

Do not use batteries that weigh less than the original equipment. Batteries are used as counterweight and are critical to machine stability. Each battery box, including batteries, must weigh a minimum of 220kg.

Do not place or attach fixed or overhanging loads to any part of this machine.

Do not place ladders or scaffolds in the platform or against any part of this machine.

Do not transport tools and materials unless they are evenly distributed and can be safely handled by person in the platform.

Do not use the machine on a moving or mobile surface or vehicle.

Be sure all tires are in good condition, castle nuts are properly tightened.

Do not push the machine or other objects with

the boom.

Do not contact adjacent structures with the boom.

Do not tie the boom or platform to adjacent structures.

Do not place loads outside the platform perimeter.



▲ Crushing Hazard

Keep hands and limbs out of mast.

Keep hands clear when lower rails.

Do not work under the platform.

Use common sense and planning when operating the machine with the controller from the ground.

Maintain safe distances between the operator, the machine and fixed objects.

▲ Operation on Slopes Hazard

Do not drive the machine on a slope that exceeds the slope and side slope rating of the machine.

Slope rating applies to machines only in the stowed position.

Model	Maximum slope rating stowed position	Maximum side slope rating stowed position
MV080J	25%	10%
MV095J	25%	10%

Note: Slope rating is subject to ground conditions and adequate traction.

Safety Rules

▲ Fall Hazard

The guard rail system provides fall protection. During operation, occupants in the platform must wear a full body harness with a lanyard attached to an authorized lanyard anchorage point. Attach only one (1) lanyard per lanyard anchorage point.



Keep the platform floor clear of debris.

Close the entry gate before operating.

Do not enter the platform unless the guard rails are properly installed and the entry is secured for operation.

Do not sit, stand or climb on the platform guard rails. Maintain a firm footing on the platform floor at all times.



Do not climb down from the platform when raised.

Do not exit the platform while raised. If a power failure occurs, have ground personnel activate the manual lowering valve.

Use extreme caution when entering or leaving platform. Be sure that the boom is fully lowered. Face the machine, maintain "three point contact" with the machine, using two hands and one foot or two feet and one hand during entry and exit.

▲ Collision Hazard



Operators must comply with employer, job site and governmental rules regarding the use of personal protective equipment.

Be aware of limited sight distance and blind spots when driving or operating.

The machine must be on a level surface or secured before releasing the brakes.

Check the work area for overhead obstructions or other possible hazards.



Be aware of crushing hazards when grasping the platform guard rail.

Do not lower the platform unless the area below is clear of personnel and obstructions.

Keep non-operating personnel at least 6 ft. (1.8m) away from machine during all driving and swing operations.



Limit travel speed according to the condition of the ground surface, congestion, slope, location of personnel, and any other factors which may cause collision.

Do not operate a machine in the path of any

Safety Rules

crane or moving overhead machinery unless the controls of the crane have been locked out and / or precautions have been taken to prevent any potential collision.

No stunt driving or horseplay while operating a machine

⚠ Bodily Injury Hazard

Do not operate the machine with a hydraulic oil or air leak. An air leak or hydraulic leak can penetrate and / or burn skin.

Improper contact with components under any cover will cause serious injury. Only trained maintenance personnel should access compartments. Access by the operator is only advised when performing a pre-operation inspection. All compartments must remain closed and secured during operation.

⚠ Explosion and Fire Hazard

Charge the battery only in an open, well-ventilated read away from sparks, flames and lighted tobacco.

Do not operate the machine or charge the battery in hazardous locations or locations where potentially flammable or explosive gases or particles may be present.

⚠ Damaged Machine Hazard

Do not use a damaged or malfunctioning machine.

Conduct a thorough pre-operation inspection of the machine and test all functions before each work shift. Immediately tag and remove from service a damaged or malfunctioning machine.

Make sure all maintenance has been performed as specified in this manual.

Make sure all decals are in place and legible.

Make sure the operator's, safety, and responsibilities manuals are complete, legible and in the storage container located on the platform.

⚠ Component Damage Hazard

Do not use the machine as a ground for welding.

⚠ Battery Safety

⚠ Burn Hazard

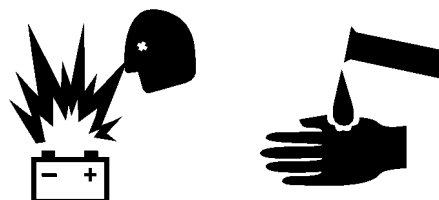

Batteries contain acid. Always wear protective clothing and eye wear when working with batteries.

Avoid spilling or contacting battery acid. Neutralize battery acid spills with baking soda and water.

The battery pack must remain in the upright position.

Do not expose the batteries or the charger to water or rain during charging.

⚠ Explosion Hazard



Keep sparks flames and lighted tobacco away from batteries. Batteries emit an explosive gas.

Safety Rules

The battery tray should remain open during the entire charging cycle.

Do not contact the battery terminals or the cable clamps with tools that may cause sparks.

▲ Component Damage Hazard

Do not use any battery charger greater than 24V to charge the batteries in the chassis.

▲ Electrocuting/Burn Hazard



Connect the battery charger to a grounded, AC 3-wire electrical outlet only.

Inspect daily for damaged cords, cables and wires.

Replace damaged items before operating.

Avoid electrical shock from contact with battery terminals. Remove all rings, watches and other jewelry.

▲ Tip-over Hazard

Do not use batteries that weigh less than the original equipment. Batteries are used as counterweight and are critical to machine stability. The battery box, including batteries, must weigh a minimum of 220kg.

▲ Lifting Hazard

Use the appropriate number of people and proper lifting techniques when lifting batteries.

▲ Pollute Hazard

Dispose of old battery must comply with job site and governmental rules.

▲ Lockout after Each Use

- 1 Select a safe parking location — firm level surface, clear of obstruction and traffic.
- 2 Lower the Jib boom and the mast to the stowed position

- 3 Rotate the turntable so that the platform is between the non-steer wheels.

- 4 Turn the key switch to the off position and remove the key to secure from unauthorized use.

- 5 Chock the wheels.

Legend

Legend

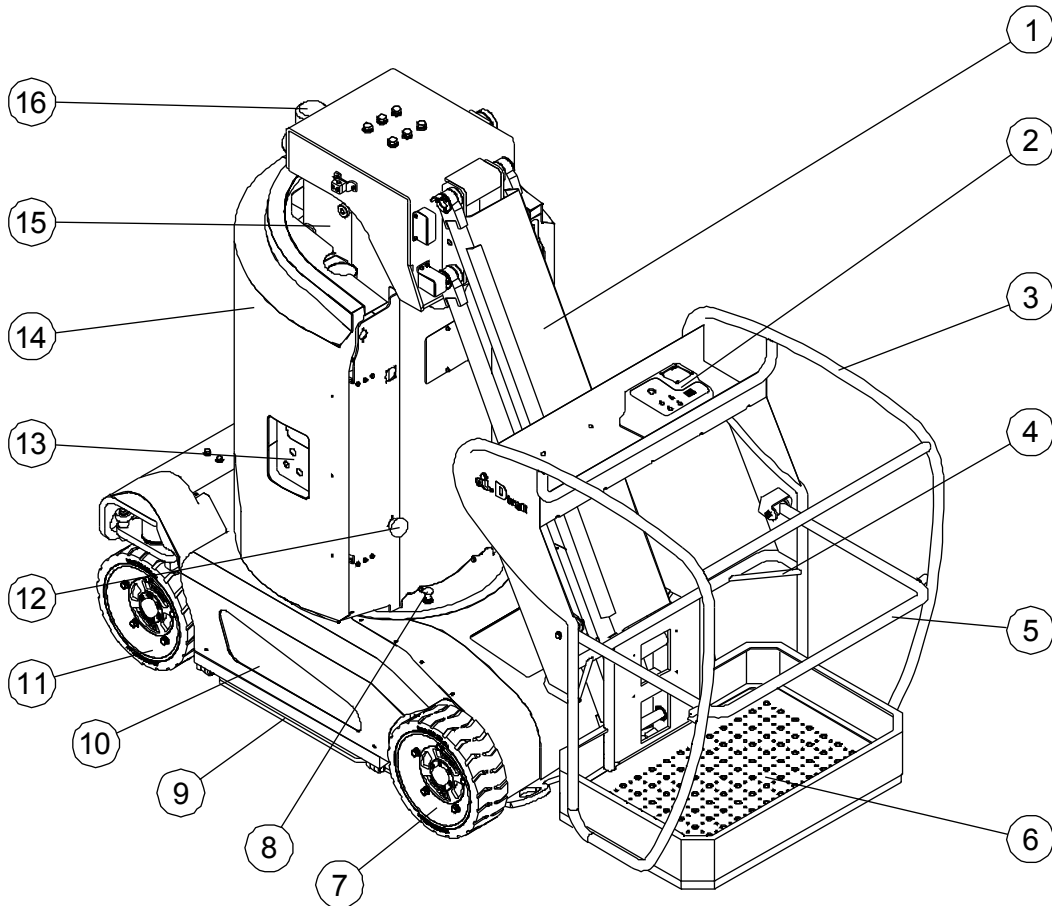

1	Jib boom	10	Chassis
2	Platform controls	11	Steer tire
3	Platform guard rails	12	Red Emergency Stop button
4	Lanyard anchorage point	13	Ground controls
5	Platform entry mid rail	14	Motor/Pump/Reservoir Unit(Located under the turntable covers, and not displayed)
6	Platform	15	Mast
7	Drive tire	16	Flashing beacon
8	Mast emergency lowering knob		
9	Pothole device		

Decal Inspection

Use the pictures on the next page to verify that all decals are legible and in place.

Below is a numerical list with quantities and descriptions.

No.	Part No.	Description	Qty.	Remark
1	9514011	Cosmetic – Mark	1	
2	9324011	Label – Open / Close	1	
3	9334011	Notice – Operator's Manual Storage	1	
4	9434085	Label –Lanyard Anchorage	2	
5	9414109	Caution – Max. Manual Force: 400N (Indoor) 200N (Outdoor)	1	
6	9314013	Instructions – Refer the operator to the instructions for use	2	
7	9424105	Warning – Tip-over Hazard	1	
8	9424107	Warning – Crushing Hazard/ Falling Hazard	1	
9	9424101	Danger – Tip-over Hazard	1	
10	9424011	Label – Capacity 200kg	1	
11	9424103	Danger – Electrocutation Hazard	1	
12	9121035	Label – Platform Console Panel	1	
13	9411021	Warning – Injection Hazard	1	
14	9421015	Caution – Forklift Pockets	4	
15	9311041	Instructions – Wheel Load: 1600kg	4	
16	9311015	Instructions – Tie Down Point	4	
17	9311013	Instructions – Lift Point	4	
18	9421013	Warning – Do not step	3	
19	9311017	Instructions – Emergency Lower	1	
20	9213013A	Decal – Manufacturer's Plate	1	
21	9311105	Label – Main Power switch operating	1	
22	9421019	Danger – Do not stand	1	

Decals

No.	Part No.	Description	Qty.	Remark
23	9421017	Warning – Crushing Hazard	1	
24	9421011	Danger – Tip-over Hazard	2	
25	9411013	Warning – Inspected and Operation Properly	1	
26	9124025	Label – Ground Console Panel	1	
27	9411011	Danger – Explosion/Burn Hazard	1	On the Battery Box
28	9432013	Warning – Crushing Hazard	1	

Decals

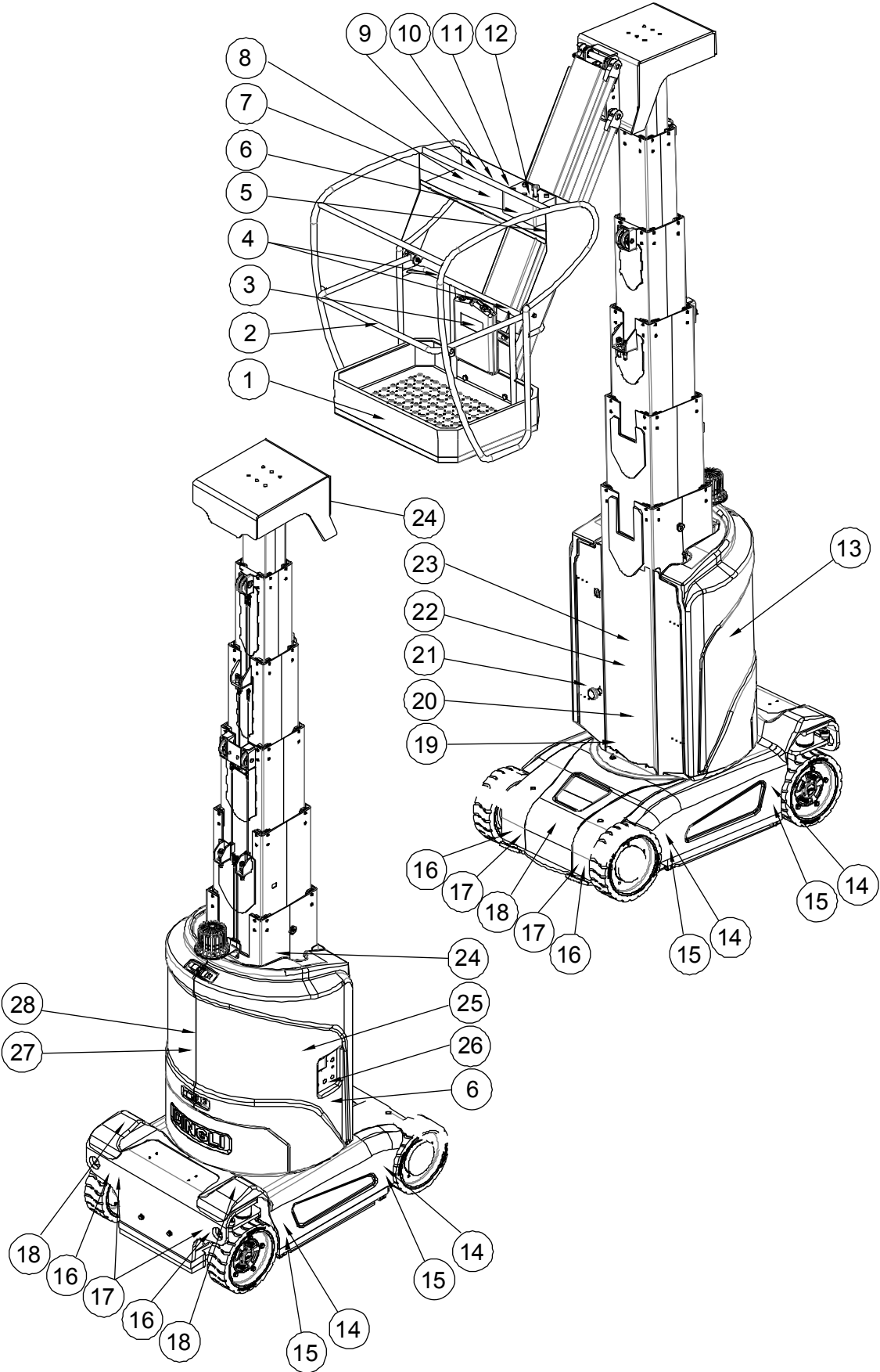

Decals

MV080J, MV095J

Platform

① 9514011

② 9324011

⑤ 9414109

⑦ 9424105

③ 9334011

④ 9434085

⑥ 9314013

⑧ 9424107

⑩ 9424011

⑨ 9424101

⑪ 9424103

⑫ 9121035

Chassis

⑬ 9411021

⑭ 9421015

⑮ 9311041

⑰ 9311013

⑱ 9311017

⑲ 9311017

⑳ 9213013A

㉑ 9411013

㉒ 9421017

㉓ 9311015

㉔ 9421019

㉕ 9421011

㉖ 9124025

㉗ 9411011

㉘ 9432013

Specifications**MV080J**

Height, working maximum	10.0m	Airborne noise emissions	<70dB
Height, platform maximum	8.0m	Maximum sound level at normal operating workstations (A-weighted)	
Height, stowed maximum	1.99m	Maximum slope rating, stowed position	25%
Height, guard rails	1.1m	Maximum side slope rating, stowed position	10%
Width	1.0 m	Note: Slope rating is subject to ground conditions and adequate traction.	
Length, stowed	2.62m	Maximum working slope	X-3°, Y-3°
Platform dimensions, (length x width)	0.62×0.87m	Drive speeds	
Maximum load capacity,	200kg	Stowed, maximum	4.5km/h
Maximum wind speed	12.5m/s	Platform raised, maximum	0.5km/h
Wheelbase	1.22m	Floor loading information	
Turntable rotation	345°	Tire load, maximum	1600kg
Jib working range	130°	Tire contact pressure	15.7kg/cm ² 1543kPa
Turning radius	1.8m	Occupied floor pressure	2207.1kg/m ² 21.6kPa
Ground clearance	6cm	Note: Floor loading information is approximate and does not incorporate different option configurations. It should be used only with adequate safety factors.	
Weight	2890kg	Continuous improvement of our products is a DINGLI policy. Product specifications are subject to change without notice or obligation.	
Machine weights vary with option configurations			
Power source	24V 240AH		
System voltage	24V		
Controls	Proportional		
Maximum hydraulic pressure	200 bar		
Tire size	Φ381×127mm		

Specifications

MV095J

Height, working maximum	11.2m	Airborne noise emissions	<70dB
Height, platform maximum	9.2m	Maximum sound level at normal operating workstations (A-weighted)	
Height, stowed maximum	1.99m	Maximum slope rating, stowed position	25 %
Height, guard rails	1.1m	Maximum side slope rating, stowed position	10 %
Width	1.0m	Note: Slope rating is subject to ground conditions and adequate traction.	
Length, stowed	2.62m	Maximum working slope	x-2.5°, y-2.5°
Platform dimensions, (length x width)	0.62×0.87m	Drive speeds	
Maximum load capacity,	200kg	Stowed, maximum	4.5 km/h
Maximum wind speed	12.5m/s	Platform raised, maximum	0.5km/h
Wheelbase	1.22m	Floor loading information	
Turntable rotation	345°	Tire load, maximum	1600kg
Jib working range	130°	Tire contact pressure	16.2kg/cm ² 1591.5kPa
Turning radius	1.8m	Occupied floor pressure	2250kg/m ² 22.1kPa
Ground clearance	6cm	Note: Floor loading information is approximate and does not incorporate different option configurations. It should be used only with adequate safety factors.	
Weight	2950kg	Continuous improvement of our products is a DINGLI policy. Product specifications are subject to change without notice or obligation.	
Machine weights vary with option configurations			
Power source	24V 240AH		
System voltage	24V		
Controls	Proportional		
Maximum hydraulic pressure	200 bar		
Tire size	Φ381×127mm		

Ground Control Panel

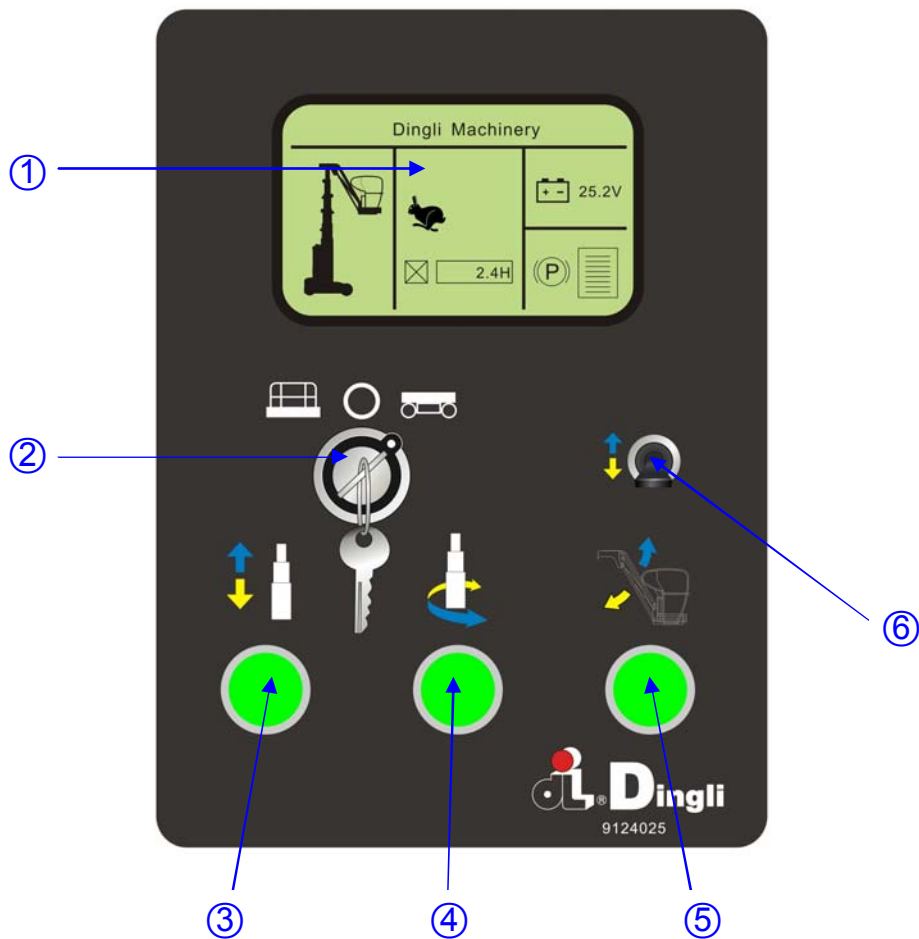

- | | |
|---|--|
| <p>1 LED
Diagnostic read out and battery charge indicator.</p> <p>2 Key switch for platform / off / ground control selection
Turn the key switch to the Platform position and the platform controls will be activated. Turn the key switch to the OFF position to cut off the power. Turn the key switch to the Chassis position and the Ground controls will be activated.</p> <p>3 Mast telescoping select button
Push and hold the button to active Mast elevation/lowering function</p> | <p>4 Turntable rotation select button
Push and hold the button to active the turntable rotation function</p> <p>5 Jib lifting/lowering select button
Push and hold the button to active the jib lifting/lowering function</p> <p>6 Movement select switch
Move upwards: mast elevation, counter clockwise turntable rotation or jib elevation;
Move downwards: mast lowering, clockwise turntable rotation or jib lowering</p> |
|---|--|

Control Panel

Platform Control Panel

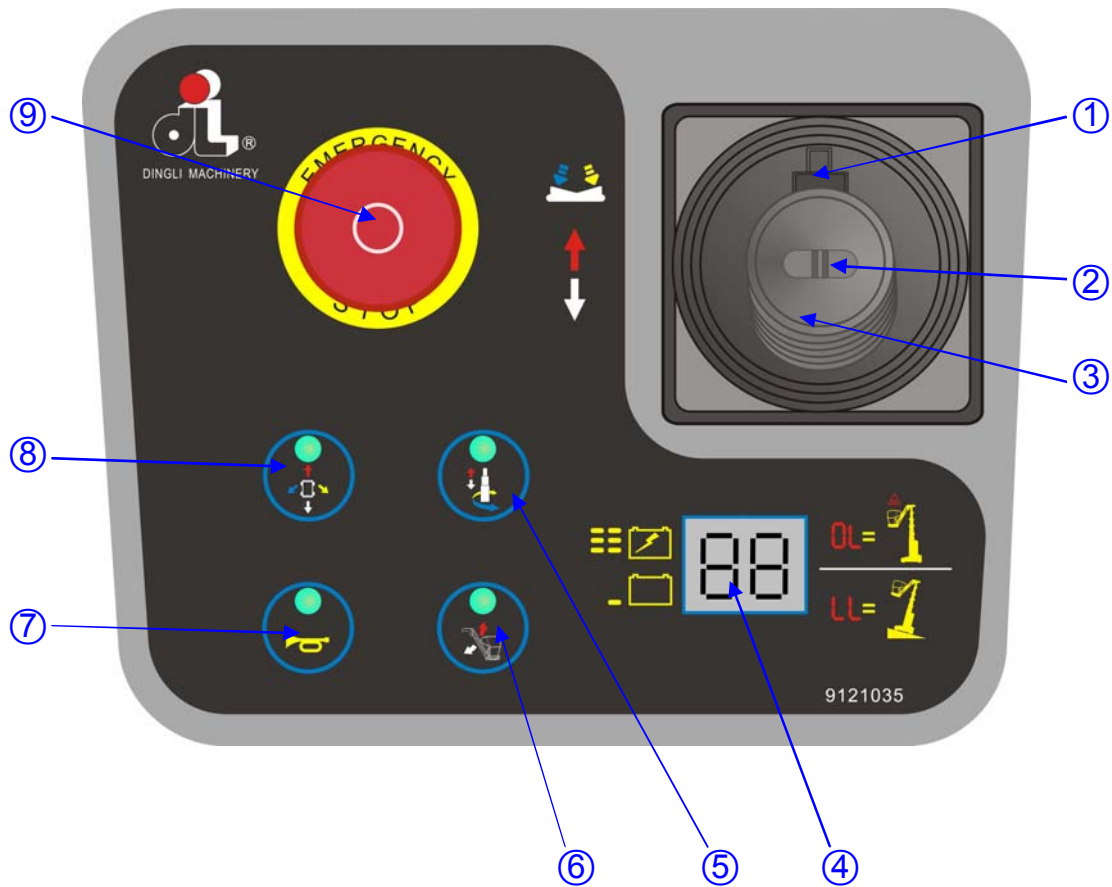

- | | | | |
|---|---|---|------------------------------------|
| 1 | Function enable switch | 6 | Jib lifting/lowering select button |
| 2 | Thumb rocker switch | 7 | Horn button |
| 3 | Proportional control handle | 8 | Drive function select button |
| 4 | LED | 9 | Red Emergency Stop button |
| 5 | Mast telescoping and Turntable rotation select button | | |

Control Panel

Platform Control Panel

- 1 Function enable switch

Lift function: Press and hold the function enable switch to enable the lift function on the platform control handle. Move the control handle in the direction indicated by the red arrow and the platform will rise. Move the control handle in the direction indicated by the white arrow and the platform will lower. The descent alarm should sound while the platform is lowering.

Drive function: Press and hold the function enable switch to enable the drive function on the platform control handle. Move the control handle in the direction indicated by the blue arrow on the control panel and the machine will move in the direction that the blue arrow points. Move the control handle in the direction indicated by the yellow arrow on the control panel and the machine will move in the direction that the yellow arrow points.
- 2 Thumb rocker switch

Press the thumb rocker switch in either direction to activate steer function.

Press the thumb rocker switch in either direction to activate swing function.
- 3 Proportional control handle
- 4 LED

Diagnostic read out and battery charge indicator.
- 5 Mast telescoping and Turntable rotation select button

Push the Turntable rotate left/right function select button to active the Turntable rotate left/right function.
- 6 Jib lifting/lowering select button

Push the Jib boom up/down function select button to active the Jib boom up/down function
- 7 Horn Button

Push the horn button and the horn will sound. Release the horn button and the horn will stop.
- 8 Drive function select button

Press this button to activate the drive function.
- 9 Red Emergency Stop button

Push in the red Emergency Stop button to the off position to stop all functions. Pull out the red Emergency Stop button to the on position to operate the machine.

Pre-operation Inspection



Do Not Operate Unless:

You learn and practice the principles of safe machine operation contained in this operator's manual.

- 1 Avoid hazardous situations.
- 2 Always perform a pre-operation inspection.**

Know and understand the pre-operation inspection before going on to the next section.

- 3 Inspect the workplace.
- 4 Always perform function tests prior to use.
- 5 Only use the machine as it was intended.

Fundamentals

It is the responsibility of the operator to perform a pre-operation inspection and routine maintenance.

The pre-operation inspection is a visual inspection performed by the operator prior to each work shift. The inspection is designed to discover if anything is apparently wrong with a machine before the operator performs the function tests.

The pre-operation inspection also serves to determine if routine maintenance procedures are required. Only routine maintenance items specified in this manual may be performed by the operator.

Refer to the list on the next page and check each of the items.

If damage or any unauthorized variation from factory delivered condition is discovered, the machine must be tagged and removed from service.

Repairs to the machine may only be made by a qualified service technician, according to the manufacturer's specifications. After repairs are completed, the operator must perform a pre-operation inspection again before going on to the function tests.

Scheduled maintenance inspections shall be performed by qualified service technicians, according to the manufacturer's specifications and the requirements listed in this manual.

Pre-operation Inspection

Pre-operation Inspection

- Be sure that the operator's manual are complete, legible and in the storage container located in the platform.
- Be sure that all decals are legible and in place. See Decals section.
- Check for hydraulic oil leaks and proper oil level. Add oil if needed. See Maintenance section.
- Check for battery fluid leaks and proper fluid level. Add distilled water if needed. See Maintenance section.

Check the following components or areas for damage, improperly installed or missing parts and unauthorized modifications:

- Electrical components, wiring and electrical cables
- Hydraulic hoses, fittings, cylinders and manifolds
- Battery pack and connections
- Drive motors
- Wear pads
- Wheels
- Lifting chains and idler wheels
- Mast and mast braces
- Limit switches, alarms and horn
- Nuts, bolts and other fasteners
- Platform entry gate and guard rail
- Alarms and beacons (if equipped)
- Platform Control Panel
- Pothole guard

Check entire machine for:

- Cracks in welds or structural components
- Dents or damage to machine
- Be sure that all structural and other critical components are present and all associated fasteners and pins are in place and properly tightened.

Workplace Inspection



Do Not Operate Unless:

You learn and practice the principles of safe machine operation contained in this operator's manual.

- 1 Avoid hazardous situations.
- 2 Always perform a pre-operation inspection.
- 3 Inspect the workplace.**

Know and understand the workplace inspection before going on to the next section.

- 4 Always perform function tests prior to use.
- 5 Only use the machine as it was intended.

Fundamentals

The workplace inspection helps the operator determine if the workplace is suitable for safe machine operation. It should be performed by the operator prior to moving the machine to the workplace.

It is the operator's responsibility to read and remember the workplace hazards, then watch for and avoid them while moving, setting up and operating the machine.

Workplace Inspection

Be aware of and avoid the following hazardous situations:

- Drop-offs or holes
- Bumps, floor obstructions or debris
- Sloped surfaces
- Unstable or slippery surfaces
- Overhead obstructions and high voltage conductors
- Hazardous locations
- Inadequate surface support to withstand all load forces imposed by the machine
- Wind and weather conditions
- The presence of unauthorized personnel
- Other possible unsafe conditions

Function Tests



Do Not Operate Unless:

You learn and practice the principles of safe machine operation contained in this operator's manual.

- 1 Avoid hazardous situations.
- 2 Always perform a pre-operation inspection.
- 3 Inspect the workplace.
- 4 **Always perform function tests prior to use.**

Know and understand the function tests before going on to the next section.

- 5 Only use the machine as it was intended.

Fundamentals

The function tests are designed to discover any malfunctions before the machine is put into service.

The operator must follow the step-by-step instructions to test all machine functions.

A malfunctioning machine must never be used. If malfunctions are discovered, the machine must be tagged and removed from service.

Repairs to the machine may only be made by a qualified service technician, according to the manufacturer's specifications.

After repairs are completed, the operator must perform a pre-operation inspection and function tests again before putting the machine into service.

Function Tests

- 1 Select a test area that is firm, level and free of obstruction.
- 2 Be sure the battery pack is connected.

At the Ground Controls

- 3 Pull out the platform and ground red Emergency Stop buttons to the on position.
- 4 Turn the key switch to ground control.
- 5 Observe the diagnostic LED readout on the ECU window.

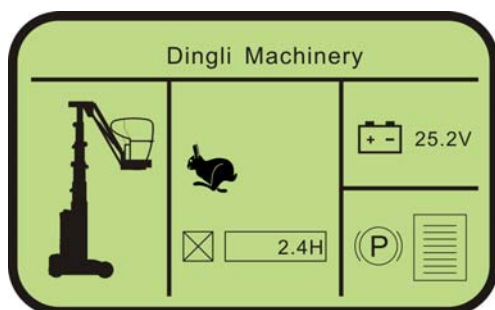

- ⊙ Result: The LED should look like the picture as the figure above.

Test Emergency Stop

- 6 Push in the ground red Emergency Stop button to the off position.
- ⊙ Result: No functions should operate.
- 7 Pull out the red Emergency Stop button to the on position.

Test Machine Functions

- 8 Do not press and hold any of the function enables buttons. Attempt to activate each function.
- ⊙ Result: All functions should not operate.
- 9 Press and hold the mast telescoping select button, move upwards/downwards the movement select switch.
- ⊙ Result: The functions should operate through a full cycle. The descent alarm should sound while the mast is lowering/ rising.

- 10 Press and hold the turntable rotation select button, move upwards/downwards the movement select switch.

- ⊙ Result: The functions should operate through a full cycle. The descent alarm should sound while the mast is rotate left/ right.

- 11 Press and hold the jib lifting/lowering select button, move upwards/downwards the function enable button

- ⊙ Result: The functions should operate through a full cycle. The descent alarm should sound while the mast is lowering/ rising.

At the Platform Controls

Test Emergency Stop

- 12 Push in the platform red Emergency Stop button to the off position.
- ⊙ Result: No functions should operate.
- 13 Pull the red Emergency Stop button out to the on position.

- ⊙ Result: The LED indicator light should come on.

Test the Horn

- 14 Push the horn button.

- ⊙ Result: The horn should sound.

Test Function Enable and Up/Down Functions

- 15 Do not hold the function enable switch on the control handle.

- 16 Slowly move the control handle in the direction indicated by the red arrow, then in the direction indicated by the white arrow.

- ⊙ Result: No functions should operate.

Function Tests

- 17 Press the jib lifting/lowering select button.
- 18 Press and hold the function enable switch on the control handle.
- 19 Move the control handle in the direction indicated by the red arrow
- ⊙ Result: The jib should rise.
- 20 Release the control handle.
- ⊙ Result: the platform should stop raising
- 21 Press and hold the function enable switch on the control handle. Move the control handle in the direction indicated by the white arrow.
- ⊙ Result: The jib should lower. The descent alarm should sound while the jib is lowering.
- 22 Press the mast telescoping and Turntable rotation select button.
- 23 Press and hold the function enable switch on the control handle. Move the control handle in the direction indicated by the red arrow.
- ⊙ Result: The mast should raise .The pothole guards should deploy.
- 24 Release the control handle.
- ⊙ Result: the mast should stop raising
- 25 Press and hold the function enable switch on the control handle. Move the control handle in the direction indicated by the white arrow.
- ⊙ Result: The mast should lower. The descent alarm should sound while the mast is lowering.
- 26 Press and hold the function enable switch on the control handle. Depress the thumb rocker switch on top of the control handle in the direction identified by the blue left arrow on the control panel.
- ⊙ Result: The turntable should rotate to the left.
- 27 Depress the thumb rocker switch in the direction identified by the yellow right arrow on the control panel.
- ⊙ Result: The turntable should rotate to the right.

Test the Steering

- 28 Press the drive function select switch.
- 29 Press and hold the function enable switch on the control handle.
- 30 Depress the thumb rocker switch on top of the control handle in the direction identified by the blue left arrow on the control panel.
- ⊙ Result: The steer wheels should turn in the direction that the blue left arrow points on the control panel.
- 31 Depress the thumb rocker switch in the direction identified by the yellow right arrow on the control panel.
- ⊙ Result: The steer wheels should turn in the direction that the yellow right arrow points on the control panel.

Test Drive and Braking

- 32 Press and hold the function enable switch on the control handle.
- 33 Slowly move the control handle in the direction indicated by the red up arrow on the control panel until the machine begins to move, and then return the handle to the center position.
- ⊙ Result: The machine should move in the direction that the red up arrow points on the control panel, then come to an abrupt stop.
- 34 Press and hold the function enable switch on the control handle.
- 35 Slowly move the control handle in the direction indicated by the white down

Function Tests

arrow on the control panel until the machine begins to move, then return the handle to the center position.

- ⊙ Result: The machine should move in the direction that the white down arrow points on the control panel, then come to an abrupt stop.

Note: The brakes must be able to hold the machine on any slope it is able to climb.

Test Limited Drive Speed

- 36 Push the mast telescoping and Turntable rotation select button.
- 37 Press and hold the function enable switch on the control handle. Raise the mast approximately 20 cm.
- 38 Push the drive function button.
- 39 Press and hold the function enable switch on the control handle. Move the drive control handle off center.
- ⊙ Result: The maximum achievable drive speed with the mast raised should not exceed 14 cm per second.
- ⊙ If the drive speed with the platform raised exceeds 14 cm per second, immediately tag and remove the machine from service.
- 40 Lower the mast. Raise the jib boom until the platform floor is approximately 1.5m from the ground.
- 41 Slowly move the drive control handle to the full drive position.
- ⊙ Result: The maximum achievable drive speed with the mast raised should not exceed 14 cm per second.
- ⊙ If the drive speed with the platform raised exceeds 14 cm per second, immediately tag and remove the machine from service.
- 42 Lower the jib boom to the stowed position.

Manual Functions

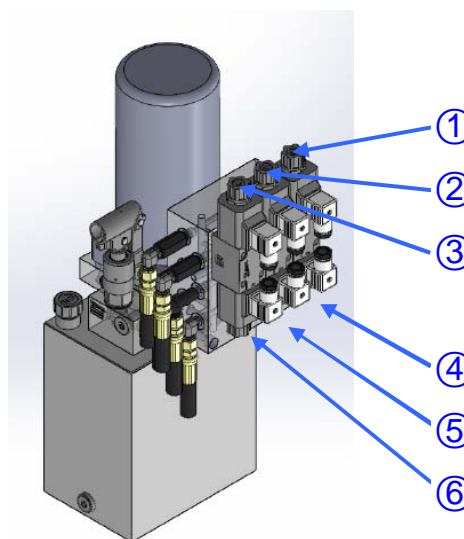

- 1 steer right valve
- 2 turntable rotate right valve
- 3 mast function valve
- 4 steer left valve
- 5 turntable rotate left valve
- 6 jib boom function valve

To rise / Lower the Mast

- 43 Open the turntable cover opposite the ground controls.
- 44 Locate the mast function valve on the function manifold.
- 45 Insert the manual hand pump handle into the pump.
- 46 While holding the button, pump the handle up and down.
- ⊙ Result: The mast should rise.
- 47 Activate the up function and raise the mast approximately 60 cm.
- 48 Pull the emergency lowering knob located the chassis.
- ⊙ Result: The platform should lower. The descent alarm will not sound.

Function Tests

To Rotate the Turntable

49 Locate the turntable rotate left valve on the function manifold.

50 Insert the manual hand pump handle into the pump.

51 While holding the button, pump the handle up and down.

☉ Result: The turntable rotate steer to the left.

52 Locate the turntable rotate right valve on the function manifold.

53 While holding the button, pump the handle up and down.

☉ Result: The turntable rotate steer to the right.

To rise/Lower the Jib Boom

54 Locate the jib boom function valve on the function manifold.

55 While holding the button, pump the handle up and down.

☉ Result: The jib boom should rise.

56 Activate the up function and raise the jib boom. Raise the jib boom until the platform floor is approximately 1.0m from the ground

57 Turn the cap on the jib boom valve counterclockwise to open the valve.

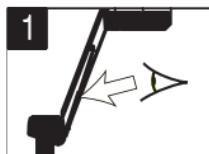

☉ Result: The platform should lower. The descent alarm will not sound.

To Steer

58 Locate the steer left valve on the function manifold.

59 Insert the manual hand pump handle into the pump.

60 While holding the button, pump the handle up and down.

☉ Result: The tires steer to the left.

61 Locate the steer right valve on the function manifold.

62 While holding the button, pump the handle up and down.

☉ Result: The tires steer to the right.

Operating Instructions



Do Not Operate Unless:

- You learn and practice the principles of safe machine operation contained in this operator's manual.
 - 1 Avoid hazardous situations.
 - 2 Always perform a pre-operation inspection.
 - 3 Inspect the workplace.
 - 4 Always perform function tests prior to use.
 - 5 **Only use the machine as it was intended.**

Fundamentals

This machine is a self-propelled hydraulic lift equipped with a work platform on the Vertical mechanism. Vibrations emitted by these machines are not hazardous to an operator in the work platform. The machine can be used to position personnel with their tools and supplies at position above ground level and can be used to reach work areas located above and over machinery or equipment.

A full and detailed implementation of EN ISO 13849-1/2 is correctly applied on our MEWP design. SISTEMA, a software tool for PL Calculation Tool, is also used to perform some relatively straightforward calculations on subsystem to determine the overall PL of the system. Reliability data, diagnostic coverage [DC], the system architecture [Category], common cause failure and, where relevant, requirements for software are used to assess the PL to comply with PLr of SRP/CS in Clause 5.11 of EN 280.

The Operating Instructions section provides instructions for each aspect of machine operation.

It is the operator's responsibility to follow all the safety rules and instructions in the operator's, safety and responsibilities manuals.

Using the machine for anything other than lifting personnel, along with their tools and materials, to an aerial work site is unsafe and dangerous.

Only trained and authorized personnel should be permitted to operate a machine. If more than one operator is expected to use a machine at different times in the same work shift, they must all be qualified operators and are all expected to follow all safety rules and instructions in the operator's, safety and responsibilities manuals. That means every new operator should perform a pre-operation inspection, function tests, and a workplace inspection before using the machine.

Operating Instructions

Emergency Stop

- 1 Push in the red Emergency Stop button to the off position at the ground controls or the platform controls to stop all machine functions.
- 2 Repair any function that operates when either red Emergency Stop button is pushed in.

Emergency Lowering

To Lower the Mast

- 3 Pull the emergency lowering knob.

To Lower the Jib Boom

- 4 Turn the cap on the jib boom valve counterclockwise to open the valve.

Operation from Ground

- 5 Turn the key switch to ground control.
- 6 Pull out the red Emergency Stop button to the on position.

To Position Platform

- 7 Push and hold the appropriate function button.
- 8 Press and hold the movement select switch.

Drive and steer functions are not available from the ground controls.

Operation from Platform

- 9 Turn the key switch to platform control.
- 10 Pull out the ground and platform red Emergency Stop buttons to the on position.
- 11 Be sure the battery pack is connected before operating the machine.

To Position Platform

To Mast

- 12 Press the mast telescoping and Turntable rotation select button.
- 13 Press and hold the function enable switch on the control handle.
- 14 Move the control handle according to the markings on the control panel.
- 15 Turn the turntable rotate with the thumb rocker switch located on the top of the control handle.

To Jib Boom

- 16 Press the jib lifting/lowering select button.
- 17 Press and hold the function enable switch on the control handle.
- 18 Move the control handle according to the markings on the control panel.

To Steer

- 19 Press the drive function select button.
- 20 Press and hold the function enable switch on the control handle.
- 21 Turn the steer wheels with the thumb rocker switch located on the top of the control handle.

To Drive

- 22 Press the drive function select button.
- 23 Press and hold the function enable switch on the control handle.
- 24 Increase speed: Slowly move the control handle off center.

Decrease speed: Slowly move the control handle toward center.

Stop: Return the control handle to center or release the function enable switch.

Use the color-coded direction arrows on the platform controls and on the platform to

Operating Instructions

identify the direction the machine will travel.

Machine travel speed is restricted when the mast or jib boom is raised.

Manual operating

To rise the Mast

- 25 Open the turntable cover opposite the ground controls.
- 26 Locate the mast function valve on the function manifold.
- 27 Insert the manual hand pump handle into the pump.
- 28 While holding the button, pump the handle up and down.

To Rotate the Turntable

- 29 Locate the turntable rotate left/right valve on the function manifold.
- 30 Insert the manual hand pump handle into the pump.
- 31 While holding the button, pump the handle up and down.

To rise the Jib Boom

- 32 Locate the jib boom function valve on the function manifold.
- 33 While holding the button, pump the handle up and down.

To Steer

- 34 Locate the steer left/right valve on the function manifold.
- 35 Insert the manual hand pump handle into the pump.
- 36 While holding the button, pump the handle up and down.

▲ Driving on a slope

Determine the slope and side slope ratings for the machine and determine the slope grade.

MV080J, MV095J

Maximum slope rating, stowed position 25%,
Maximum side slope rating, stowed position 10%

Note: Slope rating is subject to ground conditions and adequate traction.

Press the drive speed button to the fast drive speed mode.

To determine the slope grade

Measure the slope with a digital inclinometer OR use the following procedure.

You will need:

Carpenter's level

Straight piece of wood, at least 1m long

Tape measure

Lay the piece of wood on the slope.

At the downhill end, lay the level on the top edge of the piece of wood and lift the end until the piece of wood is level.

While holding the piece of wood level, measure the distance from the bottom of the piece of wood to the ground.

Divide the tape measure distance (rise) by the length of the piece of wood (run) and multiply by 100.

Example:

Run = 3.6 m

Rise = 0.3 m

$0.3 \text{ m} \div 3.6 \text{ m} = 0.083 \times 100 = 8.3\%$

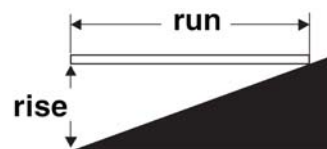

If the slope exceeds the maximum slope or side slope rating, the machine must be winched or transported up or down the slope. See Transport and Lifting section.

Operating Instructions



Battery and Charger Instructions

Observe and Obey:

- Do not use an external charger or booster battery.
- Charge the battery in a well-ventilated area.
- Use proper AC input voltage for charging as indicated on the charger.
- Use only a Dingli authorized battery and charger.

To Charge Battery

- 1 Open the turntable covers. The covers should remain open for the entire charging cycle.
- 2 Push in the red Emergency Stop button on the turntable.
- 3 Remove the battery vent caps and check the battery electrolyte level. If necessary, add distilled water to reach a level of 1 cm above the plates in each battery cell. Do not overfill.

Do not charge the batteries if the battery electrolyte temperature is above 40° C. Let the electrolyte temperature cool down first before charging the batteries.

- 4 Clean and replace the battery vent caps.
- 5 Connect the battery charger to a grounded AC power supply. Once the charging cycle begins, do not interrupt. A charge cycle of approximately 10 hours will be required for batteries discharged 70% to 80%.

- 6 The charger will indicate when the battery is fully charged.
- 7 Remove the battery vent caps and check the battery electrolyte level when the charging cycle is complete. Replenish with distilled water to reach a level of 1 cm above the plates in each cell. Do not overfill.
- 8 Replace the battery vent caps.
- 9 Disconnect the charger from the AC power supply.
- 10 Close the battery covers and latch.
- 11 Pull out the red Emergency Stop button to the on position.

Operating Instructions

Dry Battery Filling and Charging Instructions

- 1 Open the Turntable covers. The covers should remain open for the entire charging cycle.
- 2 Remove the battery vent caps and permanently remove the plastic seal from the battery vent openings.
- 3 Fill each cell with battery electrolyte until the level is sufficient to cover the plates.

Do not fill to maximum level until the battery charge cycle is complete. Overfilling can cause the battery electrolyte to overflow during charging. Neutralize battery electrolyte spills with baking soda and water.

- 4 Install the battery vent caps.
- 5 Push in the red Emergency Stop button.
- 6 Connect the battery charger to a grounded AC power supply. Once the charging cycle begins, do not interrupt.
- 7 The charger will indicate when the battery is fully charged.
- 8 Remove the battery vent caps and check the battery electrolyte level when the charging cycle is complete. Replenish with distilled water to reach a level of 1 cm above the plates in each cell. Do not overfill.

Transport and lifting instructions



Observe and Obey:

- The transport environment temperature should be within $-25^{\circ}\text{C} \sim 55^{\circ}\text{C}$
- Common sense and planning must be applied to control the movement of the machine when lifting it with a crane or forklift.
- Only qualified aerial lift operators should move the machine on or off the truck.
- The transport vehicle must be parked on a level surface.
- The transport vehicle must be secured to prevent rolling while the machine is being loaded.
- Be sure the vehicle capacity, loading surfaces and chains or straps are sufficient to withstand the machine weight. See the serial label for the machine weight.
- The machine must be on a level surface or secured before releasing the brakes.
- Only qualified forklift operators should lift the machine with a forklift.
- Be sure the crane capacity, loading surfaces and straps or lines are sufficient to withstand the machine weight. See the serial plate for the machine weight.

Brake Release Operation

- 1 Chock the wheels to prevent the machine from rolling.
- 2 Pull out the red Emergency Stop button on both the ground and platform controls to the on position.
- 3 Turn the key switch to the ground controls position.
- 4 Press the mast up/down button, meanwhile Press the Jib boom up/down button. The brake will be released after Alarm alerts.
- 5 If you want to close the brake release, just turn off the key switch in "ground" position.
- 6 Push the red Emergency stop button on both the ground and platform controls to the off position.

If the machine must be towed, do not exceed 4.5km/h.

Transport and lifting instructions

Securing to Truck or Trailer for Transit

Turn the key switch to the off position and remove the key before transporting.

Inspect the entire machine for loose or unsecured items.

Securing the Chassis

Use chains of ample load capacity.

Use a minimum of 4 chains.

Adjust the rigging to prevent damage to the chains.

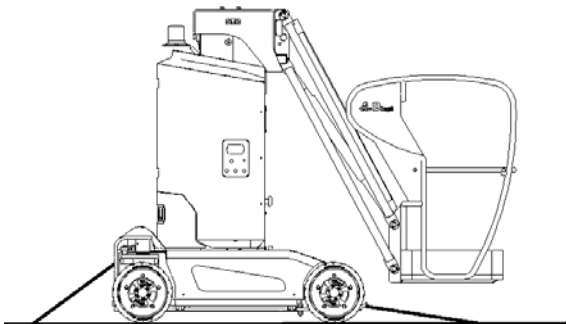
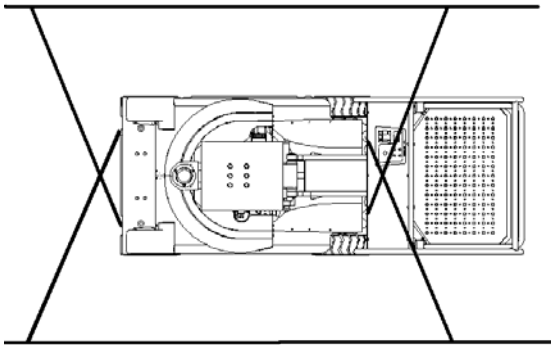

Lifting the Machine with a Forklift

Be sure the controls and component trays are secure. Remove all loose items on the machine.

Fully lower the platform. The platform must remain lowered during all loading and transport procedures.

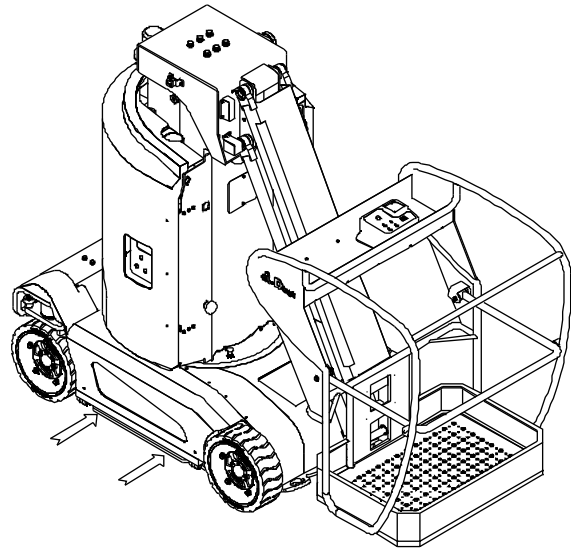

Position the forklift forks in position as the figure above.

Drive forward to the full extent of the forks.

Raise the machine 6 in / 15 cm and then tilt the forks back slightly to keep the machine secure.

Be sure the machine is level when lowering the forks.

Lifting Instructions

Fully lower the mast and jib boom. Remove all loose items on the machine.

Attach the rigging only to the designated lifting points on the machine. There are two lifting points on the top of the mast.

Adjust the rigging to prevent damage to the machine and to keep the machine level.

Transport and lifting instructions

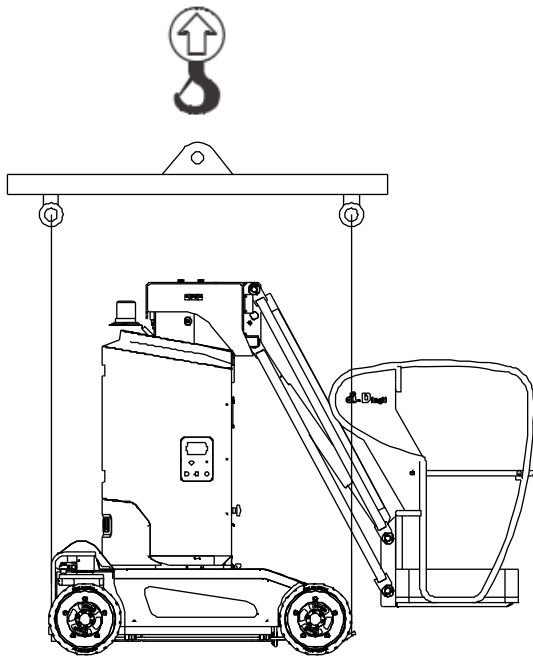

- The batteries connection should be disconnected as below. Disconnect the wire from the negative pole first, then disconnect the wires from the positive pole.
- The batteries should be connected as below: First connect the positive power wires with the positive pole, then connect the negative cable line to the negative pole.
- The batteries should be charged one time every month.

5 Rust protection

- Inspecting the paint before the machine is stored into the storage repaint the machine partly all completely against the damage.

The machine can not be used to service until it has been inspected and maintained according to the daily check procedure.

Storage procedure

The machine should be stored as bellow if it should not be used for long period.

The environment temperature should be within $-20^{\circ}\text{C}\sim 40^{\circ}\text{C}$;

The environment humidity $\leq 90\%$.

- 1 The machine should be stored indoor condition and the ground should be firm and level. If be stored in outdoor condition the machine should be covered to prevent the water and dust.
- 2 Ensure the machine have been cleaned and functional, before stop to the storage. Repair or maintain it if necessary.
- 3 Stop the machine in suitable position so as the drive or move the machines conveniently.
- 4 How to store the batteries
 - The batteries should be removed from the machine and be stored in place where it is dry and well ventilated. Keep the batteries being clean and ensure nothing being placed on the top of batteries.

Maintenance



Observe and Obey:

- Only routine maintenance items specified in this manual shall be performed by the operator.
- Scheduled maintenance inspections shall be completed by qualified service technicians, according to the manufacturer's specifications and the requirements specified in this manual.

Maintenance Symbols Legend

NOTICE

The following symbols have been used in this manual to help communicate the intent of the instructions. When one or more of the symbols appear at the beginning of a maintenance procedure, it conveys the meaning below.



Indicates that tools will be required to perform this procedure.



Indicates that new parts will be required to perform this procedure.



Indicates that dealer service will be required to perform this procedure.

Pre-delivery Preparation Report

The pre-delivery preparation report contains checklists for each type of scheduled inspection.

Make copies of the Pre-delivery Preparation report to use for each inspection. Store completed forms as required.

Maintenance Schedule

There are five types of maintenance inspections that must be performed according to a schedule— daily, quarterly, semi-annually, annually, and two year. The Scheduled Maintenance Procedures Section and the Maintenance Inspection Report have been divided into five subsections—A, B, C, D, and E. Use the following chart to determine which group(s) of procedures are required to perform a scheduled inspection.

Inspection	Checklist
Daily or every 8 hours	A
Quarterly or every 250 hours	A+B
Semi-annually or every 500 hours	A+B+C
Annually or every 1000 hours	A+B+C+D

Maintenance Inspection Report

The maintenance inspection report contains checklists for each type of scheduled inspection.

Make copies of the Maintenance Inspection Report to use for each inspection. Maintain completed forms for a minimum of 4 years or in compliance with your employer, jobsite and governmental regulations and requirements.

Maintenance

Pre-delivery Preparation Report

Fundamentals

It is the responsibility of the dealer to perform the Pre-delivery Preparation.

The Pre-delivery Preparation is performed prior to each delivery. The inspection is designed to discover if anything is apparently wrong with a machine before it is put into service.

A damaged or modified machine must never be used. If damage or any variation from factory delivered condition is discovered, the machine must be tagged and removed from service.

Repairs to the machine may only be made by a qualified service technician, according to the manufacturer's specifications.

Scheduled maintenance inspections shall be performed by qualified service technicians, according to the manufacturer's specifications and the requirements listed in this manual.

Instructions

Use the operator's manual on your machine.

The Pre-delivery Preparation consists of completing the Pre-operation Inspection, the Maintenance items and the Function Tests.

Use this form to record the results. Place a check in the appropriate box after each part is completed. Follow the instructions in the operator's manual.

If any inspection receives an N, remove the machine from service, repair and re-inspect it. After repair, place a check in the R box.

Legend

Y = yes, completed

N = no, unable to complete

R = repaired

Comments

Pre-Delivery Preparation	Y	N	R
Pre-operation inspection completed			
Maintenance items completed			
Function tests completed			

Model

Serial number

Date

Machine owner

Inspected by (print)

Inspector signature

Inspector title

Inspector company

Maintenance

Maintenance Inspection Report

Model
Serial number
Date
Hour meter
Machine owner
Inspected by (print)
Inspector signature
Inspector title
Inspector company

Instructions

- Make copies of this report to use for each inspection.
- Select the appropriate checklist(s) for the type of inspection to be performed.

<input type="checkbox"/> Daily or 8 hours Inspection:	A
<input type="checkbox"/> Quarterly or 250 hours Inspection:	A+ B
<input type="checkbox"/> Semi-annually or 500 hours Inspection:	A+B+C
<input type="checkbox"/> Annually or 1000 hours Inspection:	A+B+C+D

- Place a check in the appropriate box after each inspection procedure is completed.
- Use the step-by-step procedures in this section to learn how to perform these inspections.
- If any inspection receives an “N”, tag and remove the machine from service, repair and re-inspect it. After repair, place a check in the “R” box.

Legend

Y = yes, acceptable
 N = no, remove from service
 R = repaired

Checklist A	Y	N	R
A-1 Inspect the manuals and decals			
A-2 Pre-operation inspection			
A-3 Hydraulic Oil Level			
A-4 Function tests			
Perform after 40 hours:			
A-5 30 day service			
Checklist B	Y	N	R
B-1 Batteries			
B-2 Electrical wiring			
B-3 Tires and wheels			
B-4 Emergency stop			
B-5 Lubricate the Columns			
B-6 Key switch			
B-7 Horn			
B-8 Drive brakes			
B-9 Drive speed - stowed			
B-10 Drive speed - raised			
B-11 Flashing Beacon			
B-12 Motion Alarm			
B-13 Hydraulic oil analysis			
B-14 Breather Cap			
Checklist C	Y	N	R
C-1 Platform overload			
C-2 Breather cap - models with optional oil			
Checklist D	Y	N	R
D-1 Hydraulic oil			

Checklist A Procedures

A-1

Inspect the Manuals and Decals

Maintaining the operator's manual in good condition is essential to safe machine operation. Manuals are included with each machine and should be stored in the container provided in the platform. An illegible or missing manual will not provide safety and operational information necessary for a safe operating condition.

In addition, maintaining all of the safety and instructional decals in good condition is mandatory for safe machine operation. Decals alert operators and personnel to the many possible hazards associated with using this machine. They also provide users with operation and maintenance information. An illegible decal will fail to alert personnel of a procedure or hazard and could result in unsafe operating conditions.

- 1 Check to make sure that the operator manual is present and complete in the storage container on the platform.
 - 2 Examine the pages of manual to be sure that they are legible and in good condition.
- Result: The operator manual is appropriate for the machine and the manual are legible and in good condition.
- Result: The operator's manual is not appropriate for the machine or the manual is not in good condition or is illegible. Remove the machine from service until the manual is replaced.
- 3 Open the operator's manual to the decals inspection section. Carefully and thoroughly inspect all decals on the machine for legibility and damage.

Result: The machine is equipped with all required decals, and all decals are legible and in good condition.

Result: The machine is not equipped with all required decals, or one or more decals are illegible or in poor condition. Remove the machine from service until the decals are replaced.

- 4 Always return the manual to the storage container after use.

Note: Contact your authorized DINGLI distributor or DINGLI Industries if replacement manuals or decals are needed.

Maintenance

A-2

Perform Pre-operation Inspection

Completing a Pre-operation Inspection is essential to safe machine operation. The Pre-operation Inspection is a visual inspection performed by the operator prior to each work shift. The inspection is designed to discover if anything is apparently wrong with a machine before the operator performs the function tests. The Pre-operation Inspection also serves to determine if routine maintenance procedures are required.

Complete information to perform this procedure is available in the appropriate operator's manual. Refer to the Operator's Manual on your machine.

A-3

Check the Hydraulic Oil Level



Maintaining the hydraulic oil at the proper level is essential to machine operation. Improper hydraulic oil levels can damage hydraulic components. Daily checks allow the inspector to identify changes in oil level that might indicate the presence of hydraulic system problems.

NOTICE

Perform this procedure with the platform in the stowed position and the engine off.

- 1 Open the turntable covers of the machine.
- 2 Remove the hydraulic oil dipstick (fill cap), wipe it clean and reinstall it.
- 3 Take the hydraulic oil dipstick out again, and check the oil level.
- 4 If the hydraulic oil level is too low and add new hydraulic oil to the prescribed level.

Hydraulic oil specifications

L-HV46

A-4**Perform Function Tests**

Completing the function tests is essential to safe machine operation. Function tests are designed to discover any malfunctions before the machine is put into service. A malfunctioning machine must never be used. If malfunctions are discovered, the machine must be tagged and removed from service.

Complete information to perform this procedure is available in the appropriate operator's manual. Refer to the Operator's Manual on your machine.

A-5**Perform 30 Day Service**

The 30 day maintenance procedure is a one time procedure to be performed after the first 30 days or 40 hours of usage. After this interval, refer to the maintenance tables for continued scheduled maintenance.

- 1 Perform the following maintenance procedures:
 - B-3 Inspect the Tires, Wheels and Castle Nut Torque

Maintenance

Checklist B Procedures

B-1

Inspect the Batteries



DINGLI requires that this procedure be performed every 250 hours or quarterly, whichever comes first.

Proper battery condition is essential to good machine performance and operational safety. Improper fluid levels or damaged cables and connections can result in component damage and hazardous conditions.

⚠ WARNING Electrocutation / burn hazard. Contact with electrically charged circuits could result in death or serious injury. Remove all rings, watches and other jewelry.

⚠ WARNING Bodily injury hazard. Batteries contain acid. Avoid spilling or contacting battery acid. Neutralize battery acid spills with baking soda and water.

- 1 Put on protective clothing and eye wear.
- 2 Open the turntable covers of the machine.
- 3 Confirm that the battery cable connections are tight and free of corrosion.

Note: Adding terminal protectors and a corrosion preventative sealant will help eliminate corrosion on the battery terminals and cables.

- 4 Locate the bolts between the battery pack and the counterweight. Confirm that the head of each bolt is firmly in contact with the battery pack so that the battery pack does not move.

- 5 Remove the battery vent caps and check the battery acid level. If needed, replenish with distilled water to 3 mm below the bottom of the battery fill tube. Do not overfill.
- 6 Install the vent caps and neutralize any electrolyte that may have spilled.

B-2**Inspect the Electrical Wiring**

DINGLI requires that this procedure be performed every 250 hours or quarterly, whichever comes first.

Maintaining electrical wiring in good condition is essential to safe operation and good machine performance. Failure to find and replace burnt, chafed, corroded or pinched wires could result in unsafe operating conditions and may cause component damage.

⚠ WARNING Electrocutation / burn hazard.

Contact with electrically charged circuits could result in death or serious injury. Remove all rings, watches and other jewelry.

- 1 Open and remove the turntable covers from the machine.
- 2 Turn the key switch to ground control and pull out the red Emergency Stop button to the on position at both the ground and platform controls.
- 3 Raise the jib boom until the platform is approximately 2.5 m from the ground.
- 4 Turn the key switch to off position and push in the red Emergency Stop button to the off position at the ground control.
- 5 Tag and disconnect the cables from the ground terminal of the battery.
- 6 Remove the fasteners securing the rear chassis cover to the chassis at the non-steer end of the machine. Remove the chassis cover. Lay the cover and fasteners to the side.
- 7 Inspect the drive motors connections for burnt, chafed, pinched cables and loose connections.
- 8 Install the rear chassis cover at the non-steer end of the machine and securely install the fasteners.
- 9 Install the cables onto the ground terminal of the battery, and securely tighten.
- 10 Inspect the battery pack for burnt, chafed and pinched cables.
- 11 Inspect the following areas for burnt, chafed, corroded and loose wires:
 - Ground control panel
 - Battery charger
 - Hydraulic power unit
- 12 Turn the key switch to ground control and pull out the red Emergency Stop button to the on position at the ground control.
- 13 Lower the jib boom until the platform is approximately 0.5 m from the ground.
- 14 Turn the key switch to off position and push in the red Emergency Stop button to the off position at both the ground and platform controls.
- 15 Inspect the following areas for burnt, chafed, corroded and loose wires:
 - Mast cable
 - Platform controls
 - Power to platform wiring
- 16 Inspect for a liberal coating of dielectric grease in all wiring connections between the ground control panel and the platform controls, and level sensor wiring.
- 17 Install both the turntable covers on the machine.

Maintenance

B-3

Inspect the Tires and Wheels (including castle nut torque)



DINGLI requires that this procedure be performed every 250 hours or quarterly, whichever comes first.

Maintaining the tires and wheels in good condition is essential to safe operation and good performance. Tire and/or wheel failure could result in a machine tip-over. Component damage may also result if problems are not discovered and repaired in a timely fashion.

- 1 Check the tire surface and sidewalls for cuts, cracks, punctures and unusual wear.
- 2 Check each wheel for damage, bends and cracks.
- 3 Check each bolt for proper torque.

Bolt torque, dry	50.5Nm
Bolt torque, lubricated	37.8Nm

B-4

Test the Emergency Stop

DINGLI requires that this procedure be performed every 250 hours or quarterly, whichever comes first.

A properly functioning Emergency Stop is essential for safe machine operation. An improperly operating red Emergency Stop button will fail to shut off power and stop all machine functions, resulting in a hazardous situation.

As a safety feature, selecting and operating the ground controls will override the platform controls, except the platform red Emergency Stop button.

- 1 Turn the key switch to ground control and pull out the red Emergency Stop button to the on position at both the ground and platform controls.
 - 2 Push in the red Emergency Stop button at the ground controls to the off position.
- ⊙ Result: No machine functions should operate.
- 3 Turn the key switch to platform control and pull out the red Emergency Stop button to the on position at both the ground and platform controls.
 - 4 Push down the red Emergency Stop button at the platform controls to the off position.
- ⊙ Result: No machine functions should operate.

Note: The red Emergency Stop button at the ground controls will stop all machine operation, even if the key switch is switched to platform control.

B-5**Clean and Lubricate the Columns**

Clean and properly lubricated columns are essential to good machine performance and safe operation. Extremely dirty conditions may require that the columns be cleaned and lubricated more often.

- 1 Raise the platform to the maximum height.
- 2 Visually inspect the inner and outer channels of the columns for debris or foreign material. If necessary, use a mild cleaning solvent to clean the columns.
- 3 The bearing between chain wheel with the shaft is lubricated with the calcium base grease in raising.
- 4 Lubricate the place between chain wheel with chain used grease gun.
- 5 Lubricate the lead rail with the calcium base grease in raising.

⚠ WARNING This procedure will require the use of additional access equipment. Do not place ladders or scaffold on or against any part of the machine. Performing this procedure without the proper skills and tools may result in death or serious injury. Dealer service is strongly recommended.

B-6**Test the Key Switch**

DINGLI requires that this procedure be performed every 250 hours or quarterly, whichever comes first.

Proper key switch action and response is essential to safe machine operation. The machine can be operated from the ground or platform controls and the activation of one or the other is accomplished with the key switch. Failure of the key switch to activate the appropriate control panel could cause a hazardous operating situation.

- 1 Pull out the red Emergency Stop button to the on position at both the ground and platform controls.
- 2 Turn the key switch to platform control.
- 3 Check the machine functions from the ground controls.
 - ⊙ Result: The machine functions should not operate.
- 4 Turn the key switch to ground control.
- 5 Check the machine functions from the platform controls.
 - ⊙ Result: The machine functions should not operate.
- 6 Turn the key switch to the off position.
- 7 Test the machine functions from the ground and platform controls.
 - ⊙ Result: No function should operate.

Maintenance

B-7

Test the Automotive-style Horn (if equipped)

DINGLI requires that this procedure be performed every 250 hours or quarterly, whichever comes first.

The horn is activated at the platform controls and sounds at the ground as a warning to ground personnel. An improperly functioning horn will prevent the operator from alerting ground personnel of hazards or unsafe conditions.

- 1 Turn the key switch to platform control and pull out the red Emergency Stop button to the on position at both the ground and platform controls.
- 2 Push down the horn button at the platform controls.

⊙ Result: The horn should sound.

B-8

Test the Drive Brakes



DINGLI requires that this procedure be performed every 250 hours or quarterly, whichever comes first.

Proper brake action is essential to safe machine operation. The drive brake function should operate smoothly, free of hesitation, jerking and unusual noise.

Hydraulically-released individual wheel brakes can appear to operate normally when not fully operational.

Perform this procedure with the machine on a firm level surface that is free of obstructions, with the platform extension deck fully retracted and the platform in the stowed position.

- 1 Mark a test line on the ground for reference.
- 2 Turn the key switch to platform control and pull out the red Emergency Stop button to the on position at both the ground and platform controls.
- 3 Lower the platform to the stowed position.
- 4 Press the drive function select button.
- 5 Choose a point on the machine; i.e., contact patch of a tire, as a visual reference for use when crossing the test line.
- 6 Bring the machine to top drive speed before reaching the test line. Release the function enable switch or the joystick when your reference point on the machine crosses the test line.
- 7 Measure the distance between the test line and your machine reference point.

⊙ Result: The machine stops within the specified braking distance. No action

Maintenance

required.

- ☐ Result: The machine does not stop within the specified braking distance.

Note: The brakes must be able to hold the machine on any slope it is able to climb.

- 8 Replace the brakes and repeat this procedure beginning with step 1.

Braking distance, maximum

High range on paved surface 61cm±30cm

B-9**Test the Drive Speed - Stowed Position**

DINGLI requires that this procedure be performed every 250 hours or quarterly, whichever comes first.

Proper drive functions are essential to safe machine operation. The drive function should respond quickly and smoothly to operator control. Drive performance should also be free of hesitation, jerking and unusual noise over the entire proportionally controlled speed range.

Perform this procedure with the machine on a firm, level surface that is free of obstructions.

- 1 Create start and finish lines by marking two lines on the ground 12.2 m apart.
- 2 Turn the key switch to platform control and pull out the red Emergency Stop button to the on position at both the ground and platform controls.
- 3 Lower the platform to the stowed position.
- 4 Press the drive function select button.
- 5 Choose a point on the machine; i.e., contact patch of a tire, as a visual reference for use when crossing the start and finish lines.
- 6 Bring the machine to top drive speed before reaching the start line. Begin timing when your reference point on the machine crosses the start line.
- 7 Continue at full speed and note the time when your reference point on the machine passes over the finish line. The time is less than 10 sec.

Maintenance

B-10

Test the Drive Speed - Raised Position



DINGLI requires that this procedure be performed every 250 hours or quarterly, whichever comes first.

Proper drive functions are essential to safe machine operation. The drive function should respond quickly and smoothly to operator control. Drive performance should also be free of hesitation, jerking and unusual noise over the entire proportionally controlled speed range.

Perform this procedure with the machine on a firm, level surface that is free of obstructions.

- 1 Create start and finish lines by marking two lines on the ground 12.2 m apart.
- 2 Turn the key switch to platform control and pull out the red Emergency Stop button to the on position at both the ground and platform controls.
- 3 Press the Turntable rotate left/right and mast up/down function select button.
- 4 Press and hold the function enable switch on the joystick.
- 5 Raise the mast approximately 10 cm.
- 6 Press the drive function select button.
- 7 Choose a point on the machine; i.e., contact patch of a tire, as a visual reference for use when crossing the start and finish lines.
- 8 Bring the machine to top drive speed before reaching the start line. Begin timing when your reference point on the machine crosses the start line.
- 9 Continue at full speed and note the time when your reference point on the machine passes over the finish line. The time is less than 87sec.
- 10 Lower the mast to the stowed position.
- 11 Press the jib boom up/down function select button.
- 12 Press and hold the function enable switch on the joystick.
- 13 Raise the jib boom until the platform floor is approximately 1 .0m from the ground..
- 14 Press the drive function select button.
- 15 Choose a point on the machine; i.e., contact patch of a tire, as a visual reference for use when crossing the start and finish lines.
- 16 Bring the machine to top drive speed before reaching the start line. Begin timing when your reference point on the machine crosses the start line.
- 17 Continue at full speed and note the time when your reference point on the machine passes over the finish line. The time is less than 87sec.
- 18 Lower the jib boom to the stowed position.

Maintenance**B-11****Test the Flashing Beacon**

DINGLI requires that this procedure be performed every 250 hours or quarterly, whichever comes first.

Flashing beacon is used to alert operators and ground personnel of machine proximity and motion.

- 1 Turn the key switch to ground control and pull out the red Emergency Stop button to the on position at both the ground and platform controls.
- 2 Activate any machine function from the ground control.

⊙ Result: The beacon should flash.

- 3 Turn the key switch to platform controls.

- 4 Activate any machine function from the platform control

⊙ Result: The beacon should flash.

Note: Beacon will flash only when you activate any machine function either from ground control or platform control.

B-12**Test the Motion Alarm**

DINGLI requires that this procedure be performed every 250 hours or quarterly, whichever comes first.

Alarm is used to alert operators and ground personnel of machine proximity and motion.

- 1 Turn the key switch to ground control and pull out the red Emergency Stop button to the on position at both the ground and platform controls.

- 2 Raise the platform approximately 35 cm.

⊙ Result: When raising the platform, the motion alarm will sound.

- 3 Lower the platform to the stowed position.

⊙ Result: When lowering the platform, the motion alarm will sound.

- 4 Turn the key switch to platform controls.

- 5 Press the Turntable rotate left/right and mast up/down function select button.

- 6 Press and hold the function enable switch on the joystick. Move the joystick off center, hold for a moment and then release it. Move the joystick off center in the opposite direction, hold for a moment and then release it.

⊙ Result: The motion alarm will sound when the joystick is moved off center in either direction.

- 7 Press the drive function select button.

- 8 Press and hold the function enable switch on the joystick. Move the joystick off center, hold for a moment and then release it. Move the joystick off center in the opposite direction, hold for a moment and then release it.

⊙ Result: The motion alarm will sound when the joystick is moved off center in either direction.

Maintenance

- 9 Press and hold the function enable switch on the joystick. Press and hold the thumb rocker switch for a moment to the left position and then release it. Press and hold the thumb rocker switch for a moment to the right position and then release it.
- ⊙ Result: The motion alarm will sound when the rocker switch is moved off center in either direction.

B-13

Perform Hydraulic Oil Analysis



DINGLI requires that this procedure be performed every 250 hours or quarterly, whichever comes first.

Replacement or testing of the hydraulic oil is essential for good machine performance and service life. Dirty oil may cause the machine to perform poorly and continued use may cause component damage. Extremely dirty conditions may require oil changes to be performed more often.

Before replacing the hydraulic oil, the oil may be tested by an oil distributor for specific levels of contamination to verify that changing the oil is necessary.

If the hydraulic oil is not replaced at the two year inspection, test the oil quarterly. Replace the oil when it fails the test. See D-1, Test or Replace the Hydraulic Oil.

B-14**Inspect the Breather Cap**

DINGLI requires that this procedure be performed quarterly or every 250 hours, whichever comes first. Perform this procedure more often if dusty conditions exist.

A free-breathing hydraulic tank cap is essential for good machine performance and service life. A dirty or clogged cap may cause the machine to perform poorly. Extremely dirty conditions may require that the cap be inspected more often.

- 1 Open the turntable cover at the hydraulic power unit side of the machine.
- 2 Remove the breather cap from the hydraulic tank.
- 3 Check for proper venting.
 - ☉ Result: Air passes through the breather cap. Proceed to step 5.
 - ☐ Result: If air does not pass through the cap, clean or replace the cap. Proceed to step 4.

Note: When checking for positive tank cap venting, air should pass freely through the cap.

- 4 Using a mild solvent, carefully wash the cap venting system. Dry using low pressure compressed air. Repeat step 3.
- 5 Install the breather cap onto the hydraulic tank.
- 6 Close the cover.

Maintenance

Checklist C Procedures

C-1

Test the Platform Overload System (if equipped)



DINGLI requires that this procedure be performed every 500 hours or six months, whichever comes first or when the machine fails to lift the maximum rated load.

Testing the platform overload system regularly is essential to safe machine operation. Continued use of an improperly operating platform overload system could result in the system not sensing an overloaded platform condition. Machine stability could be compromised resulting in the machine tipping over.

⚠ WARNING Perform this procedure with the machine on a firm, level surface.

- 1 Turn the key switch to platform control and pull out the red Emergency Stop button to the on position at both the ground and platform controls.
 - ⊙ Result: The overload alarm at the platform controls should not sound, indicating a normal condition.
 - ⊗ Result: The overload alarm at the platform controls sounds. Calibrate the platform overload system.
- 2 Determine the maximum platform capacity.
- 3 Using a suitable lifting device, place an appropriate test weight equal to the maximum platform capacity in the center of the platform floor.
 - ⊙ Result: The overload alarm at the platform controls should not sound, indicating a normal condition.
 - ⊗ Result: The overload alarm at the platform controls sounds. Calibrate the platform overload system.
- 4 Add an additional weight to the platform not to exceed 10% of the maximum rated load.
 - ⊙ Result: The overload alarm at the platform controls sound, indicating a normal condition.
 - ⊗ Result: The overload alarm at the platform controls does not sound. Calibrate the platform overload system.
- 5 Test all machine functions from the platform controls.
 - ⊙ Result: All platform control functions should not operate.
- 6 Turn the key switch to ground control.
- 7 Test all machine functions from the ground controls
 - ⊙ Result: All ground control functions should not operate.
- 8 Lift the test weight off the platform floor using a suitable lifting device.
 - ⊙ Result: The overload alarm at the platform controls should not sound, indicating a normal condition.
 - ⊗ Result: The overload alarm at the platform controls sounds. Calibrate the platform overload system.
- 9 Test all machine functions from the ground controls.
 - ⊙ Result: All ground control functions should operate.
- 10 Turn the key switch to platform control.
- 11 Test all machine functions from the platform controls.
 - ⊙ Result: All platform control functions should operate.

C-2**Replace the Hydraulic Tank Breather Cap**

DINGLI requires that this procedure be performed every 500 hours or semi-annually, whichever comes first.

The hydraulic tank is a vented-type tank. The breather cap has an internal air filter that can become clogged or, over time, can deteriorate. If the breather cap is faulty or improperly installed, impurities can enter the hydraulic system which may cause component damage. Extremely dirty conditions may require that the cap be inspected more often.

- 1 Open the turntable cover at the hydraulic power unit side of the machine.
- 2 Remove and discard the hydraulic tank breather cap.
- 3 Install a new cap onto the tank.
- 4 Close the cover.

Maintenance

Checklist D Procedure

D-1

Test or Replace the Hydraulic Oil



DINGLI requires that this procedure be performed every 1000 hours or every one year, whichever comes first.

Replacement or testing of the hydraulic oil is essential for good machine performance and service life. Dirty oil may cause the machine to perform poorly and continued use may cause component damage. Extremely dirty conditions may require oil changes to be performed more often.

Before replacing the hydraulic oil, the oil may be tested by an oil distributor for specific levels of contamination to verify that changing the oil is necessary.

If the hydraulic oil is not replaced at the two year inspection, test the oil quarterly. Replace the oil when it fails the test.

Note: Perform this procedure with the platform in the stowed position.

- 1 Open the turntable cover at the hydraulic power unit side of the machine.
- 2 Disconnect the battery pack from the machine.

⚠ WARNING Electrocutation / burn hazard. Contact with electrically charged circuits could result in death or serious injury. Remove all rings, watches and other jewelry.

- 3 Remove the fasteners securing the chassis side cover next to the tank to the chassis. Remove the side cover. Lay the side cover and fasteners to the side
- 4 Place a suitable container under the hydraulic tank.

- 5 Locate and remove the hydraulic tank filler cap. Set the filler cap to the side the tank from the pump body.

- 6 Remove the drain plug and drain all of the oil into a suitable container.

⚠ WARNING Bodily injury hazard.

Spraying hydraulic oil can penetrate and burn skin. Loosen hydraulic connections very slowly to allow the oil pressure to dissipate gradually. Do not allow oil to squirt or spray.

- 7 Clean up any oil that may have spilled. Properly discard the used oil.
- 8 Clean the inside of the hydraulic tank using a mild solvent. Allow the tank to dry completely.
- 9 Install the drain plug onto the hydraulic tank and torque to specification.

Torque specifications

Hydraulic tank drain plug	5 Nm
---------------------------	------

- 10 Fill the tank with hydraulic oil until the fluid is full in the hydraulic tank. Do not overfill.
- 11 Activate the pump to fill the hydraulic system with oil and bleed the system of air.

⚠ WARNING Component damage hazard. The pump can be damaged if operated without oil. Be careful not to empty the hydraulic tank while in the process of filling the hydraulic system. Do not allow the pump to cavitate.

Maintenance**Fault Code List**

Fault Code	Description	Fault Code	Description
A 1	locore CPUa canbus fault	A 11	Right motor brake coil open circuit
A 2	locore CPUb canbus fault	A 12	Right motor brake coil short circuit
A 3	NANO canbus fault	A 13	LE70 memory P fault
A 4	Can bus off	A 14	LE70 memory R fault
A 5	Y joystick fault	A 15	Reserved
A 6	Steer Sensor Fault	A 16	zapi driver canbus fault
A 7	Jib Angle Sensor Fault	A 17	PCU canbus fault
A 8	Jib Press Sensor Fault	A 18	Jib_mA Press_fault_A
A 9	Left motor brake coil open circuit	A 19	Jib_mA Press_fault_B
A 10	Left motor brake coil short circuit	A 20	Jib_mA Press_Diff_fault

Fault Code List

Fault Code	Description	Fault Code	Description
B 3	Canview3 Canbus fault	B 30	Jib lower angle limit
B 6	Steer Sensor Fault	B 31	Serial error
B 15	LE70 Pinout fault	B 32	EEPROM KO
B 20	Lift block travel	B 33	Logic failure
B 21	Pothole Guard error	B 34	Battery low
B 22	Mast upper position limit	B 35	Drive shorted
B 23	Mast lower position limit	B 36	Contacto driver
B 24	Jib upper position limit	B 37	FORW+BACK
B 25	Anti_collision	B 38	Drive 1 KO
B 26	Anti_squeeze	B 39	Drive 2 KO
B 27	Voltage of battery less than 70%	B 40	EB1 DRV. Shorted
B 28	Manual brake release	B 41	EB2 DRV. Shorted
B 29	Jib upper angle limit	B 44	AUX DRV. Shorted

Maintenance

Fault Code List

Fault Code	Description	Fault Code	Description
B 45	EB coil shorted	B 73	Contactor closed
B 48	Output mismatch	B 74	Contactor open
B 49	Brake enable	B 75	Pump I=0 ever
B 50	Steer out of RNG.	B 76	Left STBY I high
B 51	Incorrect start	B 77	Right STBY I high
B 52	Mismatch N.	B 78	Pump STBY I high
B 53	A12 DRV. Fail	B 79	High field CUR.
B 54	AUX enable short	B 80	No field CUR.
B 55	MC enable short	B 81	Capacitor charge
B 56	MC coil open	B 82	High temperature
B 57	Wrong set BAT.	B 83	Driver 1 KO.
B 58	Analog input	B 84	Driver 2 KO.
B 59	Waiting for node	B 85	Pump I SENS. KO
B 60	No CAN MSG.	B 86	ARMDX. COIL shorted
B 61	Flash checksum	B 87	ARMSX. COIL shorted
B 62	Wrong RAM memory	B 88	V field not ok
B 63	Serial error	B 89	TH. sensor KO
B 64	Logic failure	B 90	90% Load pre-warning
B 65	Left VMN low	B 91	TRAC. SENS.KO
B 66	Left VMN high	B 92	Wait for enable
B 67	Right VMN low	B 93	Driver 3 KO
B 68	Right VMN high	B 94	TRAC. EN. shorted
B 69	Pump VMN low	B 95	Pump EN. shorted
B 70	Pump VMN high	B 96	Steer out of RN.
B 71	VMN low	B 97	Analog input
B 72	VMN high	B 98	SP. Mismatch

Fault Code List

Fault Code	Description	Fault Code	Description
B 99	No CAN MSG.	B 103	Wrong RAM. memory
B 100	Flash checksum	B 104	FLDDX coil short
B 101	Overload 220kg, PCU show "OL"	B 105	FLDSX coil short
B 102	Tilt, PCU show "LL"		

Schematic

Hydraulic Schematic

MV080J MV095J

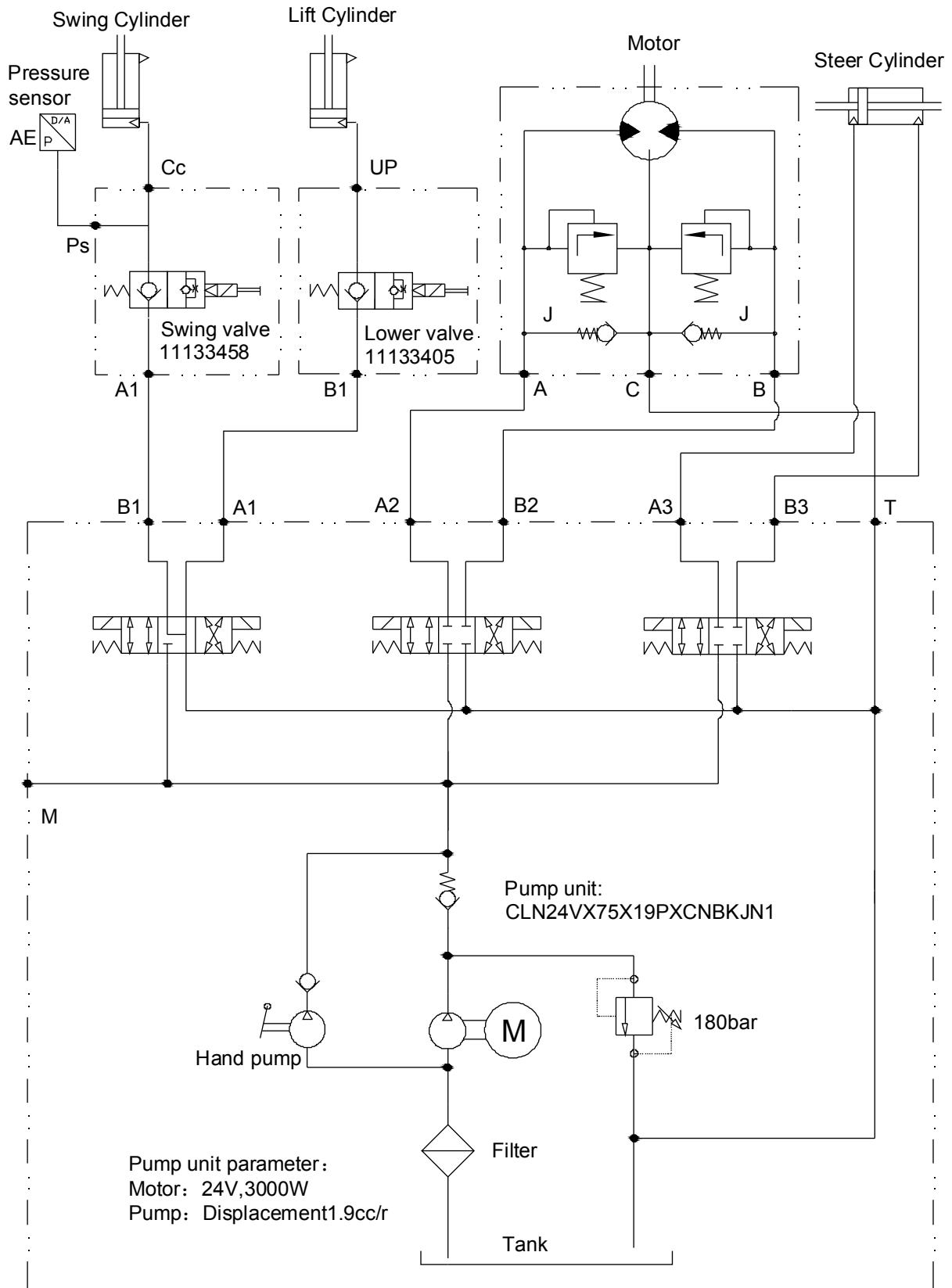

Electrical Schematic

