



**HTA13 P - HTT13 P**  
**HTA16 P - HTA19 P**



**Access on the move**

- Hydraulic outriggers and automatic leveling allow operation in under 30 seconds
- Superior combination of industry leading capacity and outreach
- Working heights from 12.7m to 18.7m

**Exceptional productivity**

- Air / water lines to the platform
- On-board generator with 240V power to the platform

**HTT13 P**

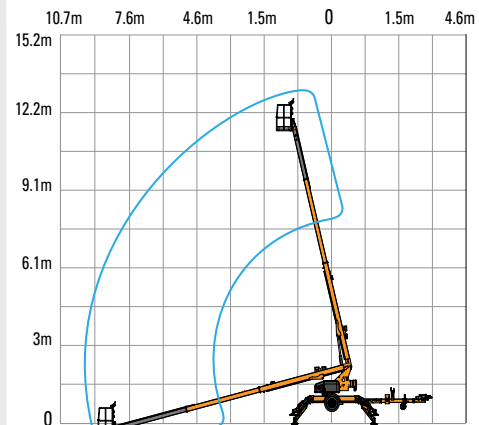

**HTA13 P - HTA16 P - HTA19 P**

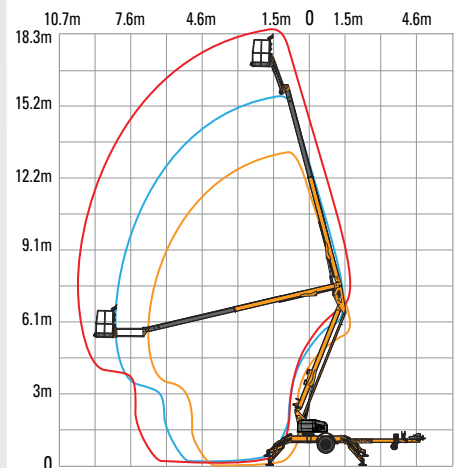

More than lifting



# HTA13 P - HTT13 P - HTA16 P - HTA19 P

## TRAILER-MOUNTED BOOMS

### TECHNICAL DATA

	HTA13P	HTT13P	HTA16P	HTA19P
Working height	12.73 m	13.26 m	15.54 m	18.67 m
Platform height	10.9 m	11.43 m	13.72 m	16.84 m
Horizontal outreach (from centerline)	6.86 m	9.75 m	8.23 m	10.19 m
Horizontal outreach (from edge of footpad)	5.31 m	8.23 m	6.40 m	8.33 m
Up and over height	5.79 m	N/A	6.33 m	7.04 m
Lift capacity	227 kg			
A - Length - stowed	4.96 m	6.68 m	5.94 m	6.99 m
B - Width stowed	1.67 m		1.70 m	
C - Height stowed	1.96 m		1.98 m	
D x E - Platform size	1.22 x 0.76 m			
F - Widest Point	3.60 m	4.19 m	4.19 m	4.47 m
G - Widest Point	3.40 m	4.11 m	4.11 m	4.57 m
Turntable rotation	350° non-continuous			
Jib - length	1.3 m	N/A	1.3 m	
Jib - Vertical Motion	150° (+70 / -80)	N/A	150° (+70 / -80)	
Tow speed rating	105 km/h			
Leveling capability	12.5 °			
Tyre size	ST 225/75 D15		ST 225/75 R15	
Power source	4 x 6 V 245 amp-hr			
Tongue weight (no options)	111 kg	91 kg	132 kg	152 kg
Weight (no options)	1542 kg	2014 kg	1905 kg	2177 kg

### STANDARD EQUIPMENT

- Hydraulic outriggers
- Automatic Levelling system
- Self-levelling platform
- Air and water line to platform
- On-board petrol generator
- 240V power to the platform
- Hydraulic surge brakes
- Spare Tyre
- Integrated forklift pockets
- Inboard 25 amp charger
- Hour meter and battery condition indicator

### OPTIONS & ACCESSORIES

- Material Lifting hook
- Platform rotator (manual)
- Tool Tray
- Electric Brakes
- Fluorescent tube caddy

