

## OPTIMUM 8



### BEST DRIVING AND LIFTING EXPERIENCE

- > AC powered
- > High precision driving
- > Proportional and quick movements
- > Best turning radius

### UTMOST VERSATILITY

- > Ability to go through standard doorways
- > Mobile potholes protection
- > Indoor - outdoor rated

### MINIMAL MAINTENANCE AND DOWNTIME

- > Maintenance free AC motors
- > 2 easy access swing-out trays
- > Haulotte Activ'Screen (onboard diagnostic)
- > Smart transportability

### LONGER LIFE TIME

- > Haulotte Activ'Energy Management takes care of your batteries
- > Extreme robustness
- > Optimized total cost of ownership



## ELECTRIC SCISSOR LIFTS

### TECHNICAL DATA

	<b>OPTIMUM 8</b>
Working height	7.77 m
Platform height	5.77 m
Max. drive working height	5.77 m
Lift capacity - inside	230 kg (2 pers.)
Lift capacity - outside	230 kg (1 pers.)
Lift capacity on the extension deck	230 kg
<b>A</b> Platform length - outside	1.72 m
<b>B</b> Platform length - extended	2.59 m
Length - extension	0.86 m
<b>C</b> Platform width - outside	0.74 m
<b>D</b> Height - stowed	1.98 m
<b>F</b> Overall width	0.79 m
<b>G</b> Length	1.9 m
<b>H</b> Wheelbase	1.38 m
<b>I</b> Ground clearance - center	8.7 cm
Ground clearance - deployed potholes	2 cm
Drive speed	0.5 - 4.5 km/h
Gradeability	25 %
Tilt	1.5° / 3°
Turning radius - outside	1.5 m
Batteries	24 V - 225 Ah
Hydraulic system capacity	7 l
Weight	1 590 kg

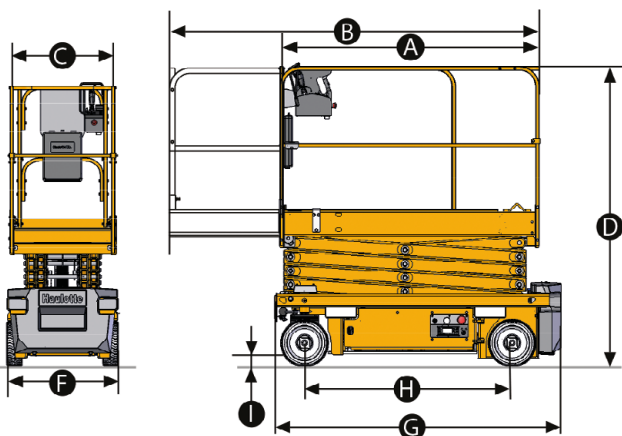

### STANDARD EQUIPMENT

- > Haulotte Activ'Energy Management: Smart CAN charger
- > 24 V electric drive brushless AC motors
- > Battery level indicator on upper and lower control boxes
- > Haulotte Activ'Screen (battery charge, hourmeter, service alert & failures icons in code or in full text...)
- > Pothole guards
- > 2 swing out trays
- > Lateral fork lifting pockets
- > 2 front steering and 2 rear driving wheels
- > Proportional controls
- > Electric or manual break release system
- > Tilt sensor
- > Lifting and stowage points
- > Non marking tyres

### OPTIONS AND ACCESSORIES

- > Haulotte Activ'Energy Management: automatic or manual batteries waterfilling system
- > Folding guardrails
- > AC power to platform
- > Hydraulic oil for cold countries
- > Telematics ready
- > Flashing light (standard in AUS / NZ)
- > Dual flashing lights
- > Working light
- > Panel carrier
- > Pipe cradle

