

## HT23 RTJ O / PRO



### OUTSTANDING PERFORMANCE & PRODUCTIVITY

- > Very good working envelope
- > 4 WD & 4 WS with 360° continuous rotation
- > Dual load basket capacity 230 - 450 kg

### BEST COMFORT AND SAFETY FEELING

- > Haulotte Activ'Shield Bar 2.0
- > Haulotte Activ'Lighting System for safe loading / unloading in conditions of low visibility
- > Quick, proportional and simultaneous movements
- > Rigid boom

### MINIMIZED TOTAL COST OF OWNERSHIP

- > Haulotte Activ'Screen diagnostic display for onboard fault & service alerts
- > Haulotte Stop Emission System automatically turns the engine off & on
- > Easy access to all components
- > Exclusive modular basket, quick and easy to repair



# HT23 RTJ O / PRO

## ROUGH TERRAIN TELESCOPIC BOOMS

### TECHNICAL DATA

	HT23 RTJ O 4WD/2WS	HT23 RTJ PRO 4WD/4WS
Working height	22.5 m	
Platform height	20.5 m	
Horizontal outreach	18.3 m	
Below ground reach	4 m	
Lift capacity	230 kg (2 pers.) - option : 450 kg (3 pers.)	
<b>F</b> x <b>G</b> Platform size	2.44 x 0.91 m	
<b>A</b> Length - stowed	10.4 m	
<b>H</b> Storage / transport length	7.8 m	
<b>B</b> Overall width	2.47 m	
<b>C</b> Height - stowed	2.7 m	
<b>I</b> Storage / transport height	3.3 m	
Vertical jib rotation	133° (+68/-65)	
Platform rotation	180° (+90/-90)	
Boom rotation angle	90° (+75/-15)	
Turntable rotation	360° continuous	
Tailswing	109 cm	
<b>D</b> Wheelbase	2.5 m	
<b>E</b> Ground clearance	34 cm	
Tilt	5°	
Drive speed	0.5 - 6.5 km/h	
Maximum wind speed rating	45 km/h	
Gradeability	40 %	
Turning radius - outside	6.3 m	3.4 m
Tyres - foam-filled	385/65 - 22.5	
Fuel tank	166 l	
Engine	Kubota 37 kW, (stage 5) ; Kubota 36.5kW (LRC & China 4)	
Weight	13 320 kg	13 400 kg

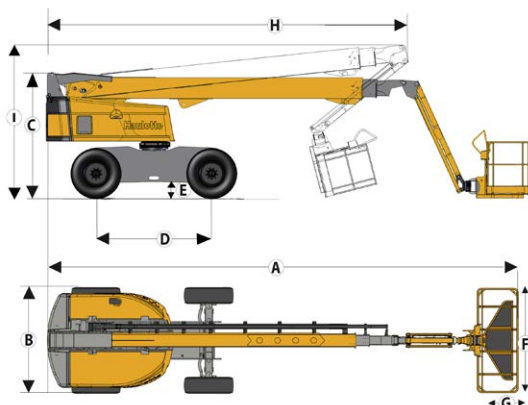

### STANDARD EQUIPMENT

- > Haulotte Activ'Lighting System
- > Haulotte Activ'Shield Bar 2.0
- > Haulotte Stop Emission System
- > Haulotte Activ'Screen onboard colored monitor screen and diagnostic system
- > Universal telematics plug
- > 4 wheel drive & 4 wheel steer with non-marking tyres
- > Front oscillating axle increases stability on uneven ground
- > Proportional controls enhance comfort and safety
- > 4 simultaneous movements for maximum productivity
- > Automatic differential wheel lock increase rough terrain capacity
- > Upper control box protection cover and tool tray in ultra-solid composite
- > Large modular basket 2.44 x 0.91 m, lateral swing door entry gate
- > Basket limitation ± 10°
- > Prepared for power to platform
- > Swing out engine tray for ease of maintenance
- > Sound and light alarm for tilt and load
- > Rotating beacon
- > Driving alarm
- > Hour meter
- > Electric pump system and emergency descent
- > 12 V battery
- > Engine pre-heater with light indicator
- > Low fuel level indicator (upper control box)

### OPTIONS AND ACCESSORIES

- > Haulotte Activ'Lighting System (standard in AUS / NZ)
- > Haulotte Activ'Shield Bar 2.0 (standard in AUS / NZ)
- > Dual load capacity 230 / 450 kg (2 - 3 persons) (standard in AUS / NZ)
- > Narrow modular platform 1.83 m x 0.8 m
- > Power to platform (female plug in the basket with or without circuit-breaker 30 mA)
- > Air line to platform
- > Drop entry gate
- > 6,5 kVA hydraulic generator (standard in AUS / NZ)
- > Biodegradable hydraulic oil
- > 60 km/h wind speed
- > Warm environment package
- > Cold weather package / kit Arctic
- > Pipe cradle pack
- > Glazier pack
- > Working lights

